

K760 Cut-n-Break

Reservdelar

Spare parts

Ersatzteile

Pieces de rechange

Piezas de repuesto

Ricambi

Peças sobresselente

No.	Pos.	Description	No.	Pos.	Description
501 00 88-01	B	SCREW	506 25 30-01	J	COMPRESSION SPRING
501 00 88-02	B	SCREW ASSY	506 25 59-03	F	TANK CAP ASSY
501 27 08-01	C	GUIDE BUSHING	506 25 81-02	J	STARTER PULLEY
501 37 13-01	F	LID	506 25 89-01	J	RECOIL SPRING
501 37 56-01	K	FLYWHEEL	506 26 22-02	G	WHEEL
501 48 54-02	K	SPARK PLUG CAP	506 26 31-01	J	SPACING SLEEVE
501 63 48-01	K	SPRING	506 26 41-01	F	FUEL FILTER
501 67 32-03	K	PAWL	506 26 41-11	F	FUEL FILTER
501 98 10-20	J	SCREW	506 27 11-01	F	HOSE CLAMP
502 28 92-03	C	DRIVING PULLEY ASSY	506 29 21-01	F	GASKET
502 29 50-02	E	CRANKSHAFT ASSY	506 29 88-01	H	FILTER
503 12 79-01	J	STARTER HANDLE	506 31 30-01	F	LABEL
503 16 40-01	F	TANK VENT	506 31 69-01	C	DUST COVER
503 20 34-19	C	SCREW	506 31 86-02	F	STOP SWITCH
503 21 27-16	G	SCREW	506 31 86-02	K	STOP SWITCH
503 21 28-10	AFJK	SCREW	506 33 56-15	J	STARTER CORD
503 21 45-16	F	SCREW	506 33 56-50	J	STARTER CORD
503 21 46-01	G	SCREW	506 35 27-02	A	PROTECTIVE SPRING
503 21 53-10	AHM	SCREW	506 36 42-04	D	MUFFLER
503 21 53-16	CDG	SCREW	506 36 88-01	D	BRACKET
503 21 53-20	KM	SCREW	506 36 97-01	M	INLET PIPE
503 21 53-21	L	SCREW	506 36 98-01	M	INLET PIPE
503 21 53-25	D	SCREW	506 37 02-01	L	COVER
503 21 53-40	DH	SCREW	506 37 04-01	L	BELLOWS
503 21 53-41	C	SCREW	506 37 05-01	M	FLANGE INLET PIPE
503 21 53-56	DGM	SCREW	506 37 06-01	M	FLANGE INLET PIPE
503 21 54-20	FH	SCREW	506 37 11-03	H	FRONT HANDLE
503 22 10-11	K	NUT	506 37 13-01	F	THROTTLE ROD
503 22 65-04	CDFM	NUT	506 37 19-02	F	BASE PLATE
503 23 00-42	K	WASHER STEEL	506 37 20-03	F	THROTTLE TRIGGER
503 23 00-70	C	WASHER	506 37 24-01	D	PISTON ASSY
503 23 01-01	K	WASHER STEEL	506 37 27-02	A	BELT
503 23 04-01	C	WASHER	506 37 58-02	D	COOLING PLATE
503 23 04-02	D	WASHER	506 37 67-01	CDMP	GASKET CYLINDER BASE
503 23 04-03	B	WASHER	506 37 68-03	CDMP	GASKET CARBURETTOR
503 23 51-09	K	SPARK PLUG	506 37 69-02	CDMP	GASKET MUFFLER
503 25 56-01	DE	NEEDLE BEARING	506 37 69-02	CDMP	GASKET MUFFLER
503 26 02-04	CDMP	SEALING RING	506 37 70-03	CDMP	GASKET CRANCASE
503 26 30-08	A	O-RING	506 37 72-02	H	SPRING RETAINER
503 26 60-03	H	COUPLING	506 37 80-01	F	GROMMET
503 26 60-04	H	COUPLING	506 37 84-02	K	CABLE
503 28 90-47	D	PISTON RING	506 37 85-01	K	CABLE
503 40 06-09	M	IMPULSE HOSE	506 37 95-01	F	SPRING
503 47 96-01	N	SCREW	506 38 15-01	F	HEAT SHIELD
503 48 00-01	N	PIN RETAINING SCREW	506 38 26-01	P	COMBINATION TOOL
503 48 11-01	N	PIECE	506 38 53-05	CDMP	GASKET KIT
503 48 18-01	N	SCREW	506 38 60-05	H	VALVE ASSY
503 53 56-01	N	PLUG WELCH	506 38 65-08	F	FUEL TANK
503 53 57-01	N	STRAINER	506 38 65-12	F	FUEL TANK
503 55 22-01	D	PLUG	506 38 66-01	F	TANK VENT ASSY
503 57 89-01	F	TANK CAP HOLDER	506 38 67-02	F	GROUND SUPPORT
503 61 66-01	N	GASKET PUMP	506 38 71-02	H	STOP
503 71 53-01	D	DECOMPRESSION VALVE	506 38 78-34	K	IGNITION CABLE
503 74 43-01	C	CLUTCH SPRING	506 39 46-02	F	CAP
503 74 44-06	C	CLUTCH ASSY	506 39 54-01	N	COLLAR
503 84 61-01	C	BUFFER	506 39 55-01	N	COVER
503 93 66-01	F	PRIMER HOUSING	506 39 56-01	N	COVER
504 35 72-01	F	SINTER PLUG	506 39 57-01	N	DIAPHRAGM ASSY
504 87 52-01	A	SEALING	506 39 58-01	N	GASKET
504 90 94-10	C	SCREW	506 39 60-01	N	DIAPHRAGM PUMP
505 09 55-03	H	HOSE KIT	506 39 61-01	N	NOZZLE ASSY
505 10 35-01	H	O-RING	506 39 62-01	N	GASKET
505 19 52-01	F	FUEL HOSE	506 39 64-01	N	QUAD RING
505 22 09-37	C	BAR BOLT	506 39 65-01	N	ROD
505 25 96-01	D	MUFFLER MOUNTING KIT	506 39 66-01	N	SCREW
505 27 75-16	K	ISOLERHATT	506 39 69-01	N	SCREW
505 42 45-01	D	VIB.INSULATOR	506 39 70-01	N	SCREW
506 00 69-01	K	SCREW	506 39 71-01	N	SHAFT ASSY
506 09 56-05	A	HOSE CLAMP	506 39 72-01	N	SCREW
506 22 28-02	F	THROTTLE LOCKOUT	506 39 73-01	N	SHAFT ASSY CHOKE

No.	Pos.	Description	No.	Pos.	Description
506 39 74-01	N	SHAFT ASSY	544 03 21-01	G	SPRAY GUARD
506 39 75-01	N	SPRING	544 03 22-01	G	PLATE
506 39 78-01	N	VALVE	544 03 92-01	G	BUSHING
506 39 79-01	N	WASHER	544 04 17-01	A	HOSE
506 39 84-05	L	CYLINDER COVER ASSY	544 06 12-01	DFH	SCREW
506 39 90-01	N	O-RING	544 08 21-01	N	SCREW
506 39 91-01	N	PLUG	544 08 22-01	N	SCREW
506 40 24-01	B	CENTER NUT	544 10 37-03	A	BAR ASSY
506 40 25-02	B	SCREW	544 10 50-04	A	HOSE ASSY
506 40 26-01	C	SCREW	544 10 59-01	A	BEARING
506 40 28-02	A	BEARING CAGE	544 17 80-02	P	TOOL
506 40 29-02	A	BUSHING	544 17 81-01	P	PULLER
506 40 33-01	C	BELT TENSIONER	544 21 93-02	CDMP	INSERT
506 40 37-01	G	BUSHING	544 22 90-02	F	CHOKE CONTROL
506 40 46-02	A	WEAR PROTECTION	544 23 82-01	F	BAND
506 40 51-01	A	STOP	544 26 53-01	B	WASHER
506 40 53-01	A	BAR PLATE	544 32 50-03	F	FUEL HOSE
506 40 55-02	A	BELT GUARD	544 35 26-01	M	PLATE
506 40 56-01	A	DEFLECTION LIMITER	544 37 44-02	A	LABEL
506 40 56-02	A	DEFLECTION LIMITER	544 38 39-01	J	AIR CONDUCTOR
506 40 57-02	A	GROMMET	544 39 32-01	F	HOSE CLIP
506 40 60-01	G	SPRING	544 83 64-01	N	PUMP COVER
506 40 61-01	A	SPRING	544 83 65-01	N	SPRING
506 40 61-02	A	SPRING	544 89 09-02	L	LABEL
506 40 63-02	G	SPRAY GUARD	574 23 14-01	L	DECAL
506 40 64-03	A	BELT GUARD	574 23 14-02	L	DECAL
506 40 65-02	A	BLADE GUARD	574 23 16-01	L	DECAL
506 40 98-02	A	NIPPLE	574 23 16-02	L	DECAL
506 40 99-01	N	GASKET KIT	574 23 16-03	L	DECAL
506 41 00-03	N	GASKET KIT CARB	574 24 09-01	C	PAWL
506 41 23-01	CDMP	GASKET	574 36 20-01	J	STARTER
506 49 87-02	H	HOSE CLAMP	574 36 21-01	L	FILTER HOLDER ASSY
510 00 08-01	J	SEALING HOLDER	574 36 23-01	M	FILTER
510 00 72-01	G	SPRAY GUARD UPPER	574 47 48-02	C	CRANK CASE ASSY
510 00 73-01	G	GUIDE PIECE	574 48 96-01	C	LABEL
510 05 66-01	G	SPRAY GUARD ASSY	574 83 62-01	B	CUTTING BLADE
510 11 56-02	K	IGNITION MODULE	574 83 62-02	B	CUTTING BLADE
510 18 12-02	MN	CARBURETTOR	574 83 62-03	B	CUTTING BLADE
510 20 20-01	G	WASHER	575 27 99-01	A	CUTTER ARM
510 20 24-01	G	BAND	575 30 31-01	H	HOSE ASSY
510 26 92-22	J	SCREW	575 33 81-01	C	BELT TENSIONER ASSY
520 75 73-04	D	CYLINDER ASSY	575 34 85-01	G	SPRAY GUARD ASSY
522 03 81-01	G	LABEL	575 35 13-01	H	HANDLE
522 47 48-01	C	WASHER	575 35 40-01	M	CARBURETTOR BRACKET
522 47 57-01	C	SPRING RETAINER	575 44 13-01	N	SPRING
522 60 75-01	N	VALVE	575 51 62-01	H	HOSE ASSY
522 83 23-01	H	GROUND SUPPORT	720 12 40-20	F	PARALLEL PIN
522 83 24-01	H	GROUND SUPPORT	724 12 84-01	A	SCREW
525 44 43-01	L	FILTER COVER	731 23 18-01	C	NUT
525 44 60-01	J	STARTER COVER	732 21 14-01	G	LOCK NUT
525 47 06-01	M	AIR FILTER PAPER	734 48 80-01	G	WASHER
525 56 45-01	A	BELT COVER	735 31 08-20	C	CIRCLIP
525 57 11-01	J	LABEL	735 31 10-41	B	CIRCLIP
525 58 43-01	L	AIR NOZZLE	737 43 12-00	D	CIRCLIP
525 61 70-02	L	SEALING	738 22 02-25	CE	BALL BEARING
525 62 39-01	C	CLUTCH COVER	740 42 05-00	G	O-RING
525 73 98-01	G	HOLDER	740 43 13-00	J	O-RING
525 76 35-02	L	DECAL			
525 83 18-01	C	BALL BEARING			
537 01 25-01	N	BALL			
537 01 26-01	N	SPRING			
537 04 24-14	F	FUEL HOSE			
537 17 62-01	N	VALVE			
537 17 64-01	N	LEVER			
537 17 70-01	N	VALVE			
537 17 78-01	N	PLUG			
537 20 33-01	E	CUP			
537 21 03-07	F	VIBRATION ABSORBER			
537 38 51-01	N	SCREW			
537 38 52-01	N	E-CLIP			

A**K760 Cut-n-Break**

29



1

2

9

10

11

12

13

3

4

5

6

7

8

14

15

17

18

19

20

16

21

22

23

10

24

25

26

27

28

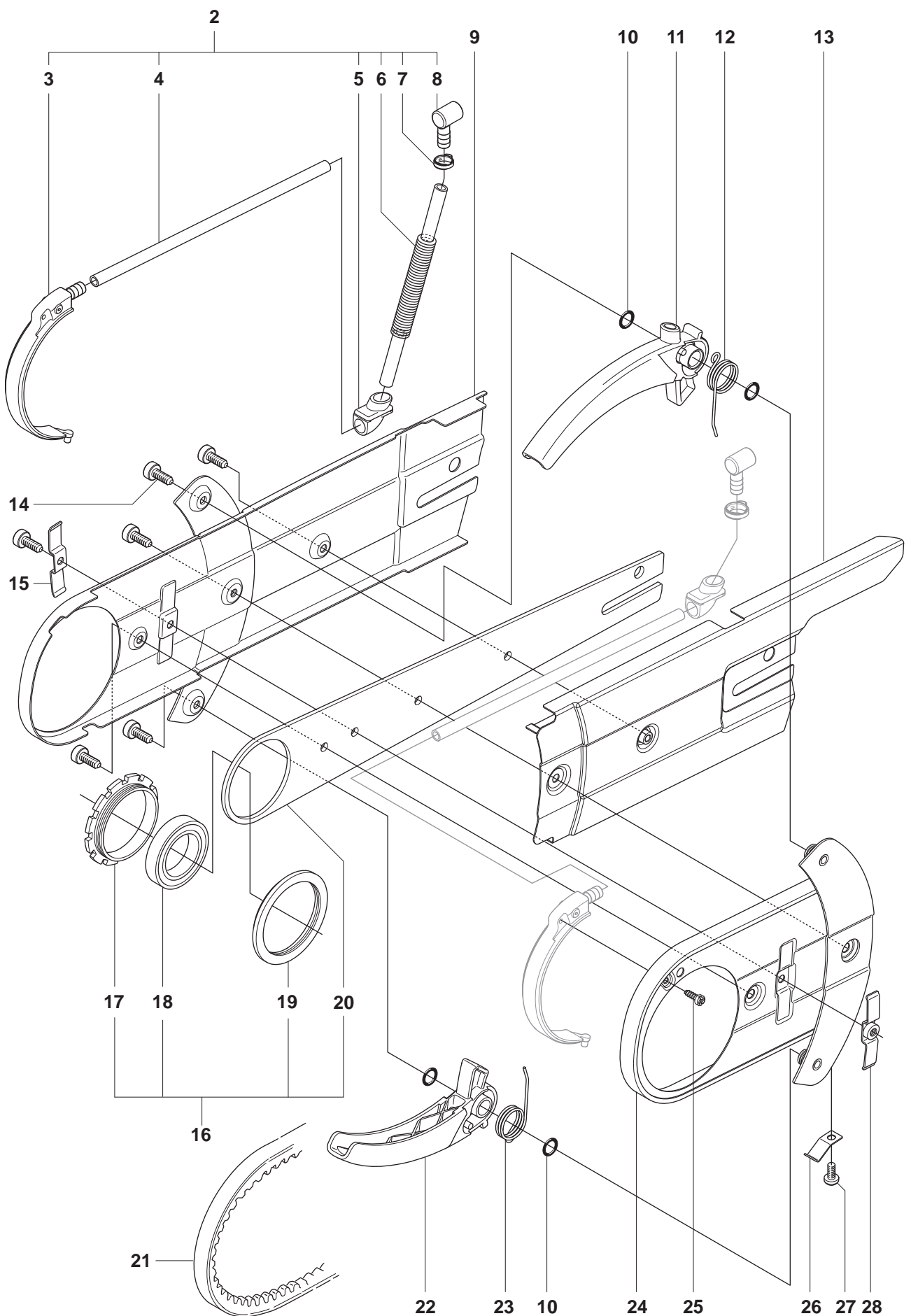

Page A**K760 Cut-N-Break**

Pos.	Part No.	Description	Quantity	Notes	New Part
1	575 27 99-01	CUTTER ARM	1	Incl. 2, 9 - 16, 21 - 28	
2	544 10 50-04	HOSE ASSY	1	Incl. 3 - 8	
3	504 87 52-01	SEALING	1		
4	544 04 17-01	HOSE	1		
5	506 40 57-02	GROMMET	1		
6	506 35 27-02	PROTECTIVE SPRING	1		
7	506 09 56-05	HOSE CLAMP	1		
8	506 40 98-02	NIPPLE	1		
9	506 40 55-02	BELT GUARD	1		
10	503 26 30-08	O-RING	2		
11	506 40 64-03	BELT GUARD	1		
12	506 40 61-01	SPRING	1		
13	525 56 45-01	BELT COVER	1		
14	503 21 53-10	SCREW	6		
15	506 40 56-01	DEFLECTION LIMITER	1		
16	544 10 37-03	BAR ASSY	1	Incl. 17 - 20	
17	506 40 28-02	BEARING CAGE	1		
18	544 10 59-01	BEARING	1		
19	506 40 29-02	BUSHING	1		
20	506 40 53-01	BAR PLATE	1		
21	506 37 27-02	BELT	1		
22	506 40 65-02	BLADE GUARD	1		
23	506 40 61-02	SPRING	1		
24	506 40 46-02	WEAR PROTECTION	1		
25	503 21 28-10	SCREW	1		
26	506 40 51-01	STOP	1		
27	724 12 84-01	SCREW	1		
28	506 40 56-02	DEFLECTION LIMITER	1		
29	544 37 44-02	LABEL	1		

B K760 Cut-n-Break

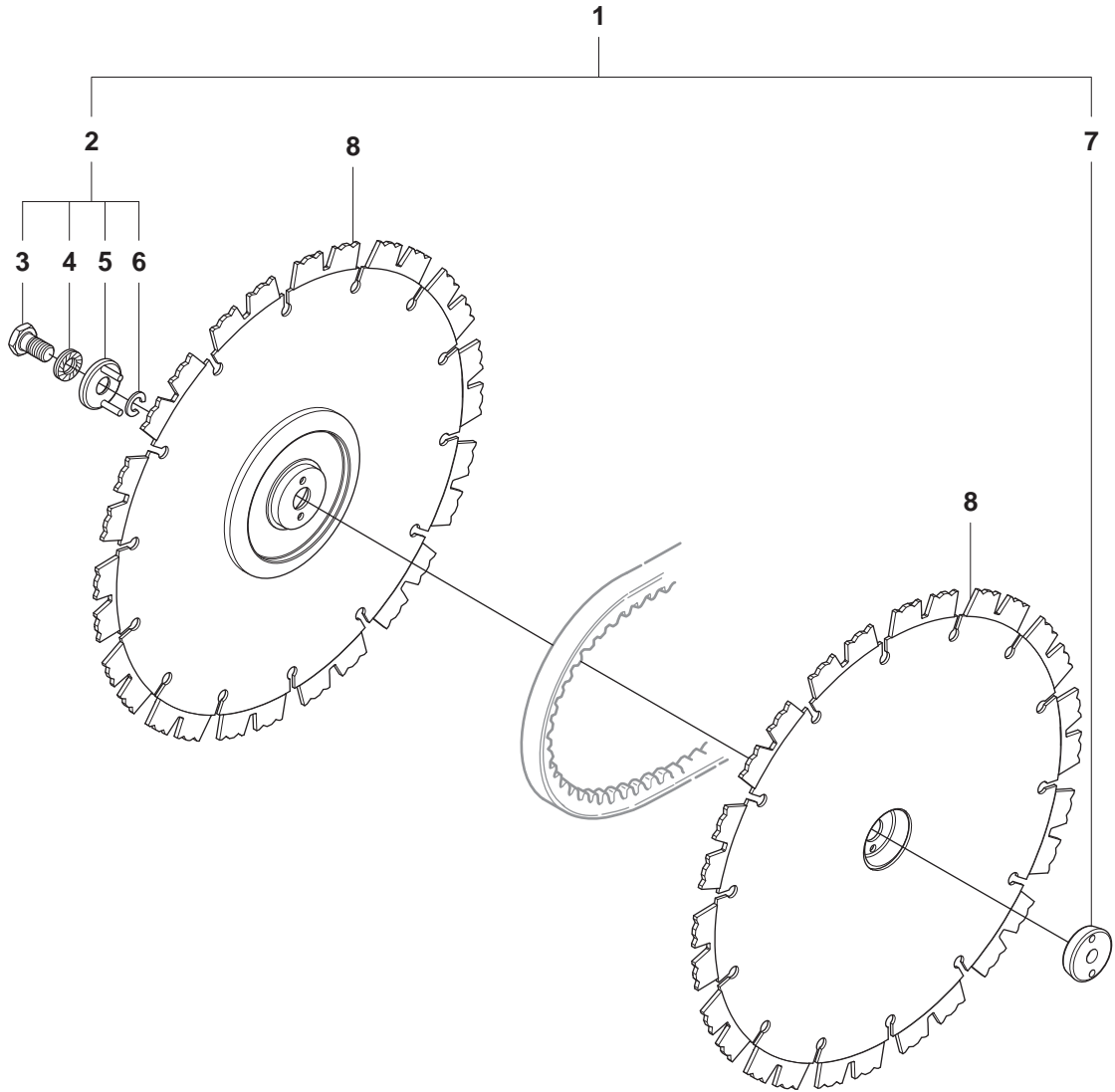

Page B**K760 Cut-N-Break**

Pos.	Part No.	Description	Quantity	Notes	New Part
1	501 00 88-02	SCREW ASSY	1	Incl. 2, 7	
2	501 00 88-01	SCREW	1		
3	506 40 25-02	SCREW	1		
4	503 23 04-03	WASHER	1		
5	544 26 53-01	WASHER	1		
6	735 31 10-41	CIRCLIP	1		
7	506 40 24-01	CENTER NUT	1		
8	574 83 62-01	CUTTING BLADE	2	EL10 CnB Soft	
8	574 83 62-02	CUTTING BLADE	2	EL35 CnB Medium	
8	574 83 62-03	CUTTING BLADE	2	EL70 CnB Hard	

C K760 Cut-n-Break

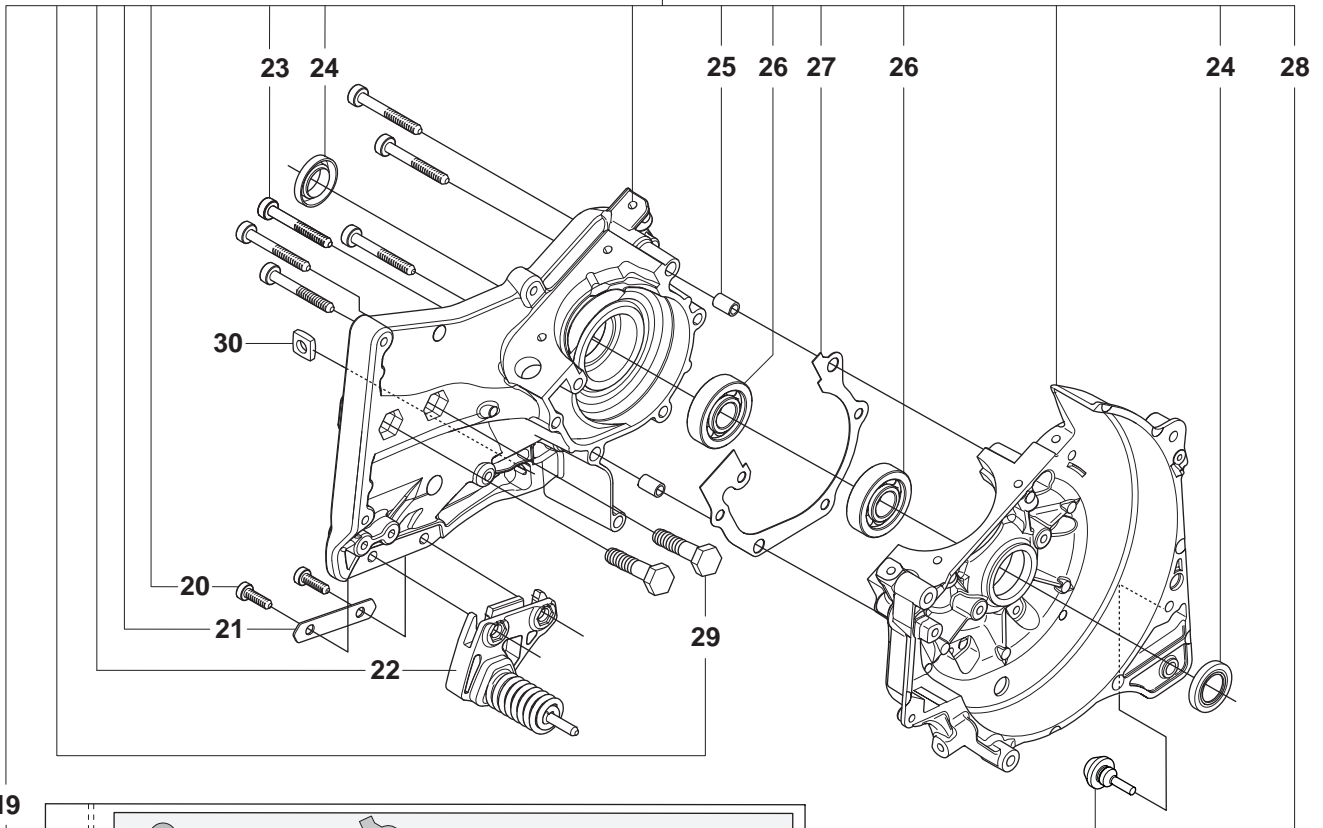
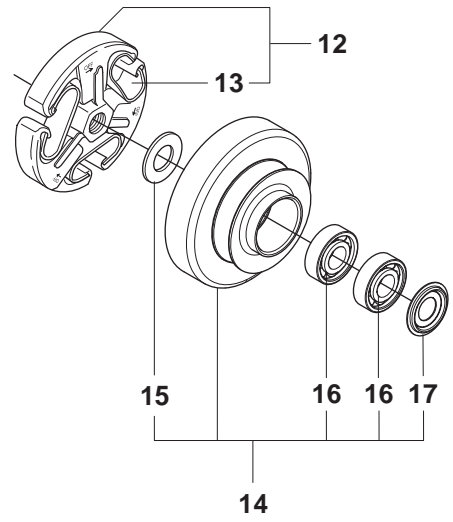
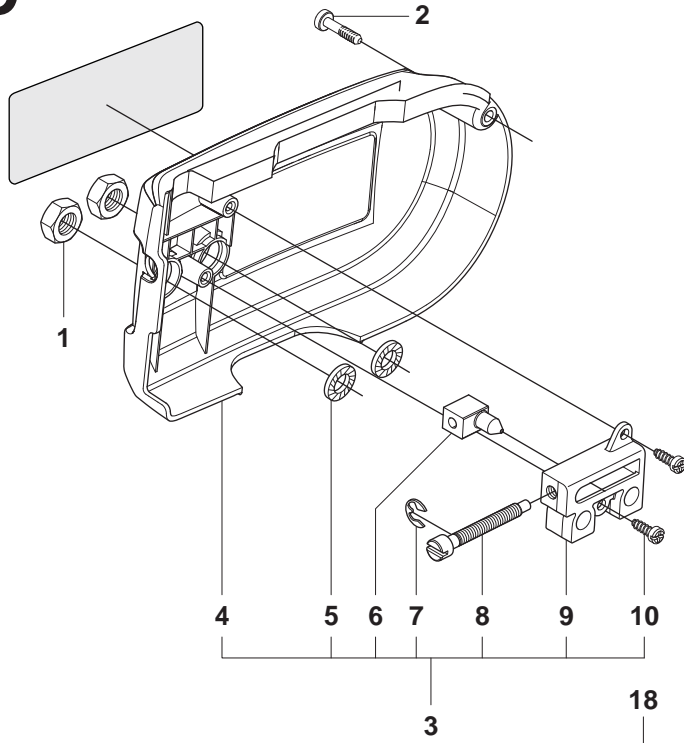

19

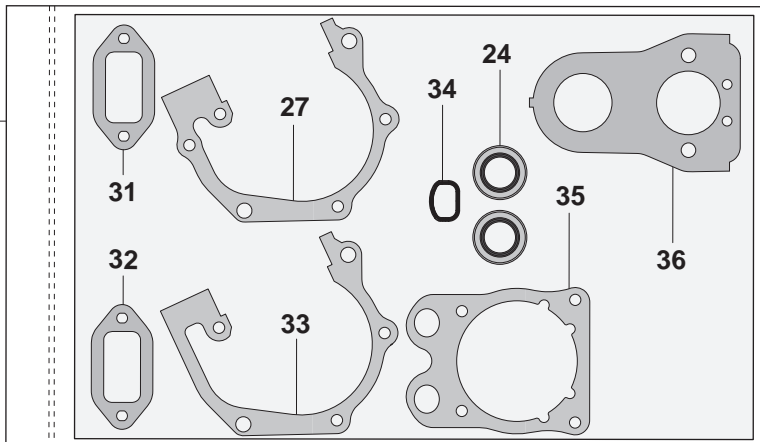

Page C**K760 Cut-N-Break**

Pos.	Part No.	Description	Quantity	Notes	New Part
1	731 23 18-01	NUT	2		
2	503 20 34-19	SCREW	1		
3	575 33 81-01	BELT TENSIONER ASSY	1	Incl. 4 - 10	
4	525 62 39-01	CLUTCH COVER	1		
5	503 23 04-01	WASHER	2		
6	574 24 09-01	PAWL	1		
7	735 31 08-20	CIRCLIP	1		
8	506 40 26-01	SCREW	1		
9	506 40 33-01	BELT TENSIONER	1		
10	504 90 94-10	SCREW	2		
11	574 48 96-01	LABEL	1		
12	503 74 44-06	CLUTCH ASSY	1	Incl. 13	
13	503 74 43-01	CLUTCH SPRING	1		
14	502 28 92-03	DRIVING PULLEY ASSY	1	Incl. 15 - 17	
15	503 23 00-70	WASHER	1		
16	525 83 18-01	BALL BEARING	2		
17	506 31 69-01	DUST COVER	1		
18	574 47 48-02	CRANK CASE ASSY	1	Incl. 19 - 29	
19	506 38 53-05	GASKET KIT	1	Incl. 24, 27, 30 - 35	
20	503 21 53-16	SCREW	2		
21	522 47 48-01	WASHER	1		
22	522 47 57-01	SPRING RETAINER	1		
23	503 21 53-41	SCREW	6		
24	503 26 02-04	SEALING RING	2		
25	501 27 08-01	GUIDE BUSHING	2		
26	738 22 02-25	BALL BEARING	2		
27	506 37 70-02	GASKET CRANKCASE	1		
28	503 84 61-01	BUFFER	1		
29	505 22 09-37	BAR BOLT	2		
30	503 22 65-04	NUT	1		
31	506 41 23-01	GASKET	1		
32	506 37 69-02	GASKET MUFFLER	1		
33	506 37 70-03	GASKET CRANKCASE	1		
34	544 21 93-02	INSERT	1		
35	506 37 67-01	CYLINDER BASE GASKET	1		
36	506 37 68-03	GASKET CARBURETTOR	1		

D K760 Cut-n-Break

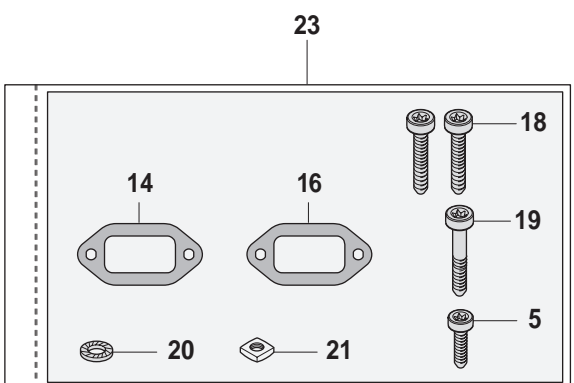
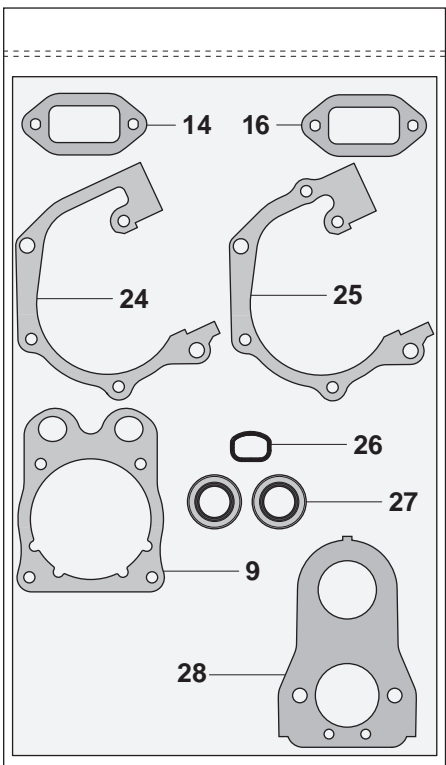
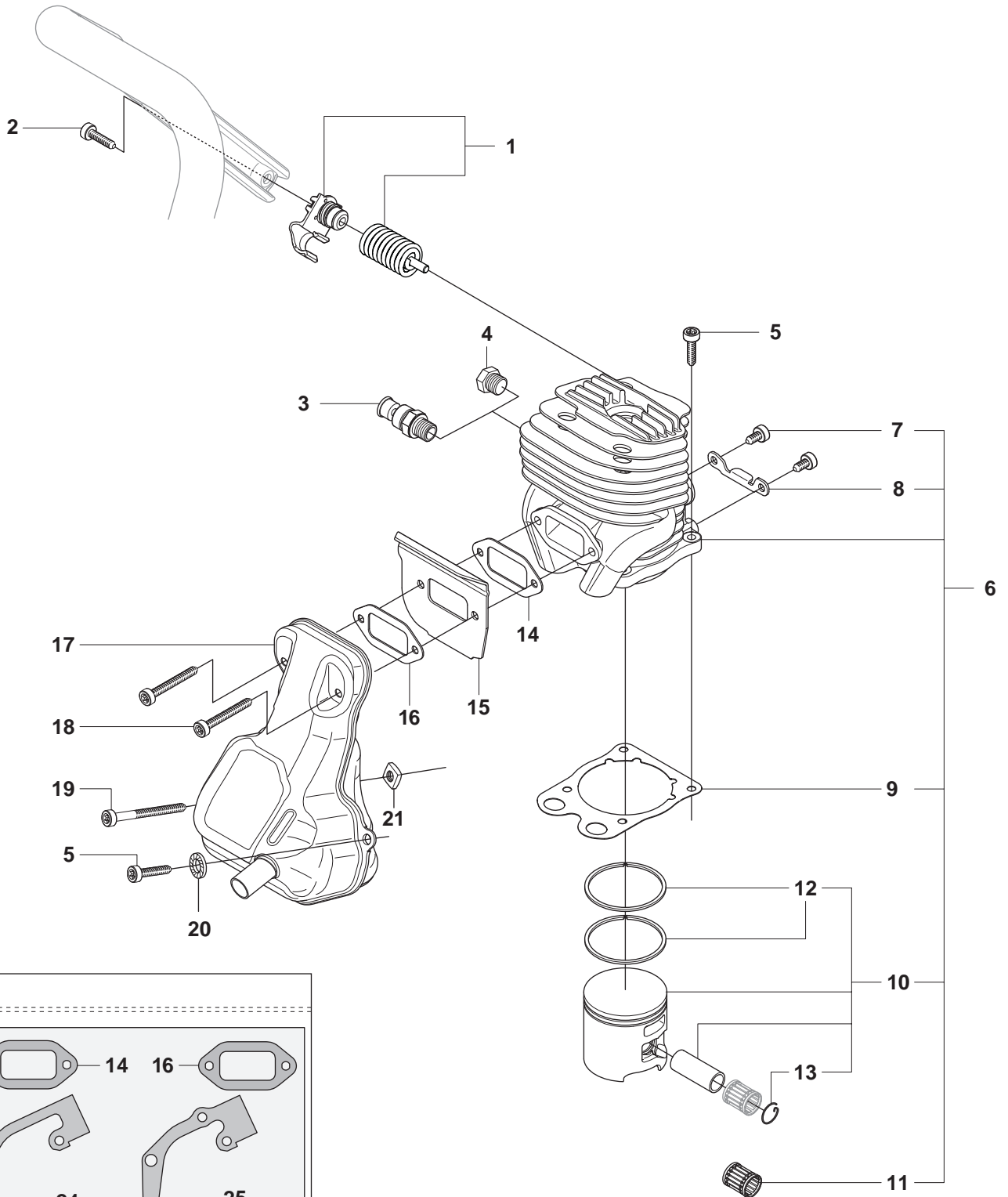

Page D**K760 Cut-N-Break**

Pos.	Part No.	Description	Quantity	Notes	New Part
1	505 42 45-01	VIB.INSULATOR	1		
2	544 06 12-01	SCREW	1		
3	503 71 53-01	DECOMPRESSION VALVE	1		
4	503 55 22-01	PLUG	1		
5	503 21 53-25	SCREW	5		
6	520 75 73-04	CYLINDER ASSY	1	Incl. 7 - 11	
7	503 21 53-16	SCREW	2		
8	506 36 88-01	BRACKET	1		
9	506 37 67-01	CYLINDER BASE GASKET	1		
10	506 37 24-01	PISTON ASSY	1	Incl. 12 - 13	
11	503 25 56-01	NEEDLE BEARING	1		
12	503 28 90-47	PISTON RING	2		
13	737 43 12-00	CIRCLIP	2		
14	506 41 23-01	GASKET	1		
15	506 37 58-02	COOLING PLATE	1		
16	506 37 69-02	GASKET MUFFLER	1		
17	506 36 42-04	MUFFLER	1		
18	503 21 53-40	SCREW	2		
19	503 21 53-56	SCREW	1		
20	503 23 04-02	WASHER	1		
21	503 22 65-04	NUT	1		
22	506 38 53-05	GASKET KIT	1	Incl. 9, 14, 16, 24 - 28	
23	505 25 96-01	MUFFLER MOUNTING KIT	1	Incl. 5, 14, 16, 18 - 21	
24	506 37 70-02	GASKET CRANKCASE	1		
25	506 37 70-03	GASKET CRANKCASE	1		
26	544 21 93-02	INSERT	1		
27	503 26 02-04	SEALING RING	2		
28	506 37 68-03	GASKET CARBURETTOR	1		

E K760 Cut-n-Break

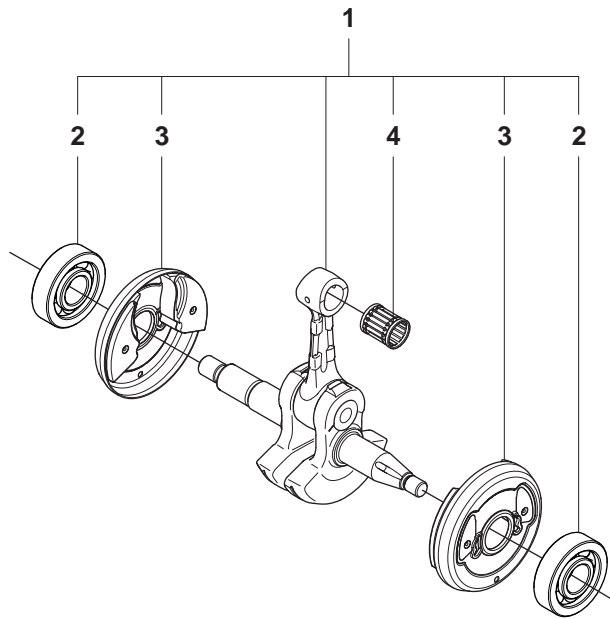

Page E**K760 Cut-N-Break**

Pos.	Part No.	Description	Quantity	Notes	New Part
1	502 29 50-02	CRANKSHAFT ASSY	1	Incl. 2 - 4	
2	738 22 02-25	BALL BEARING	2		
3	537 20 33-01	CUP	2		
4	503 25 56-01	NEEDLE BEARING	1		

F

K760 Cut-n-Break

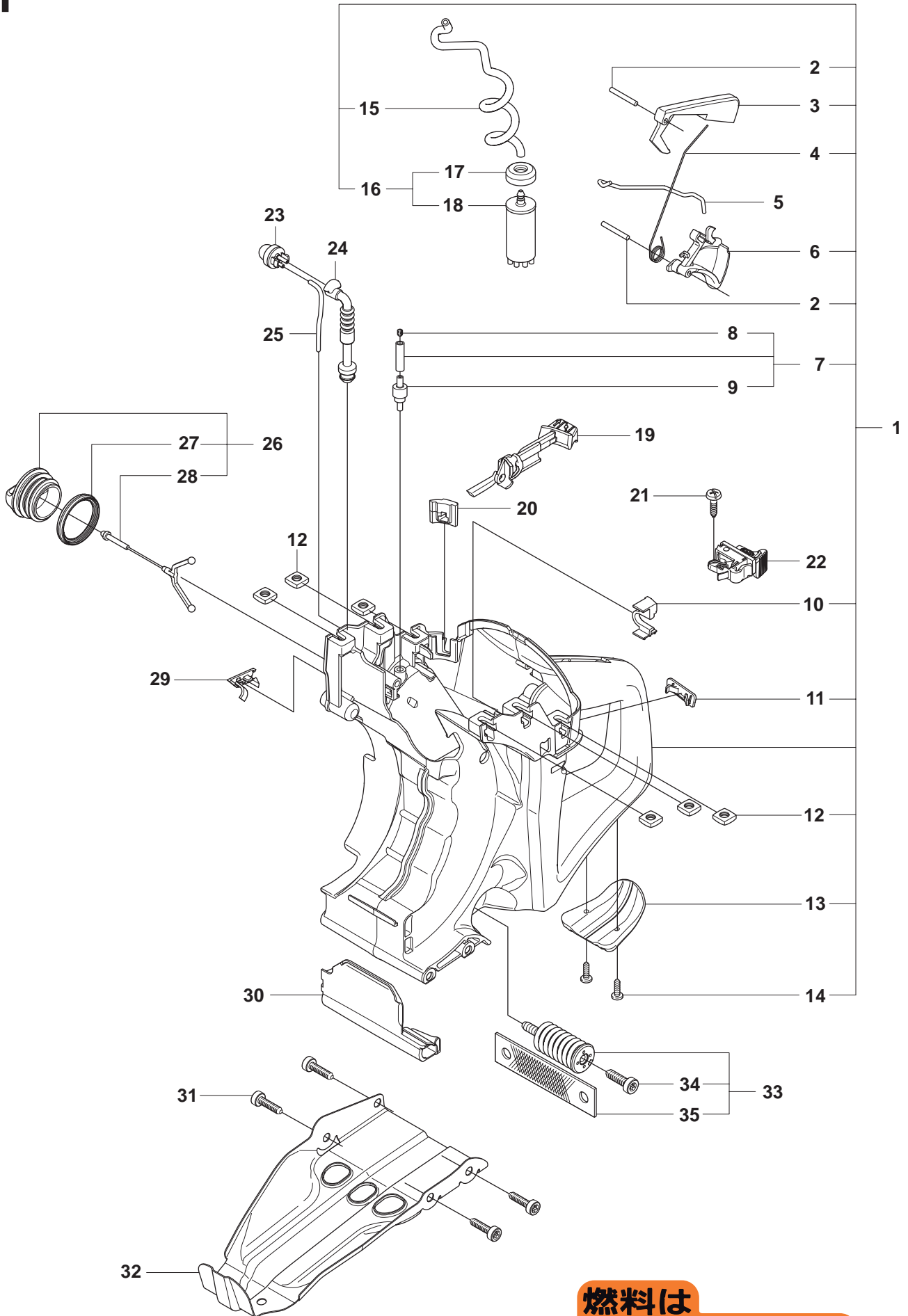
**燃料は**

ガソリン

25 : 12サイクル
専用オイル

36

Page F**K760 Cut-N-Break**

Pos.	Part No.	Description	Quantity	Notes	New Part
1	506 38 65-08	FUEL TANK	1	Incl. 2 - 4, 6 - 7, 10 - 16, Purge	
1	506 38 65-12	FUEL TANK	1	Incl. 2 - 4, 6 - 7, 10 - 16	
2	720 12 40-20	PARALLEL PIN	2		
3	506 22 28-02	THROTTLE LOCKOUT	1		
4	506 37 95-01	SPRING	1		
5	506 37 13-01	THROTTLE ROD	1		
6	506 37 20-03	THROTTLE TRIGGER	1		
7	506 38 66-01	TANK VENT ASSY	1	Incl. 8 - 9	
8	504 35 72-01	SINTER PLUG	1		
9	503 16 40-01	TANK VENT	1		
10	544 39 32-01	HOSE CLIP	1		
11	501 37 13-01	LID	1		
12	503 22 65-04	NUT	6		
13	506 38 67-02	GROUND SUPPORT	1		
14	503 21 45-16	SCREW	2		
15	544 32 50-03	FUEL HOSE	1		
16	506 26 41-11	FUEL FILTER	1	Incl. 17 - 18	
17	506 27 11-01	HOSE CLAMP	1		
18	506 26 41-01	FUEL FILTER	1		
19	544 22 90-02	CHOKE CONTROL	1		
20	506 37 80-01	GROMMET	1		
21	503 21 28-10	SCREW	1		
22	506 31 86-02	STOP SWITCH	1		
23	503 93 66-01	PRIMER HOUSING	1	Purge	
24	505 19 52-01	FUEL HOSE	1	Purge	
25	537 04 24-14	FUEL HOSE	1	Purge	
26	506 25 59-03	TANK CAP ASSY	1	Incl. 27 - 28	
27	506 29 21-01	GASKET	1		
28	503 57 89-01	TANK CAP HOLDER	1		
29	506 39 46-02	CAP	1		
30	506 38 15-01	HEAT SHIELD	1		
31	503 21 54-20	SCREW	4		
32	506 37 19-02	BASE PLATE	1		
33	537 21 03-07	VIBRATION ABSORBER	1	Incl. 34 - 35	
34	544 06 12-01	SCREW	1		
35	544 23 82-01	BAND	1		
36	506 31 30-01	LABEL	1	Japan only	

G K760 Cut-n-Break

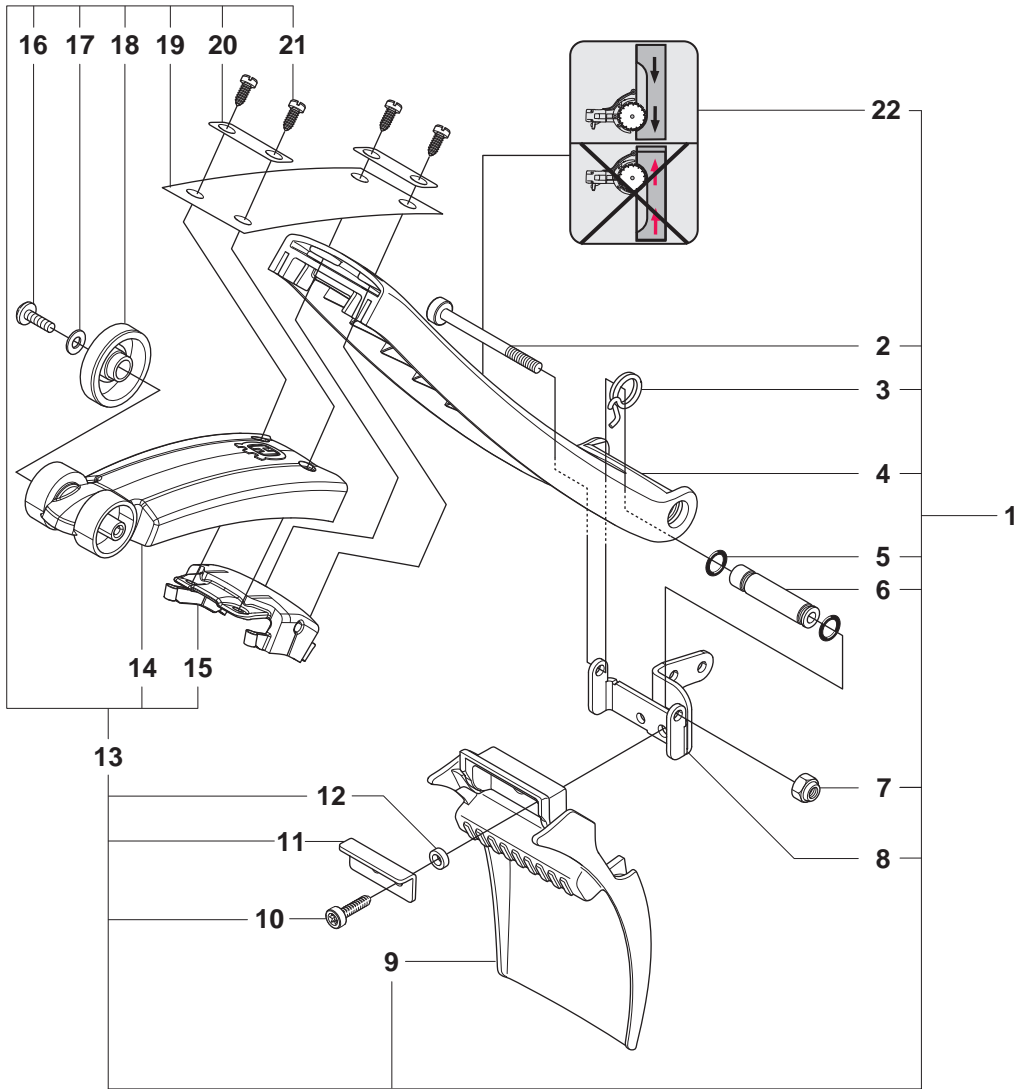

Page G**K760 Cut-N-Break**

Pos.	Part No.	Description	Quantity	Notes	New Part
1	575 34 85-01	SPRAY GUARD ASSY	1	Incl. 2 - 13, 22	
2	503 21 53-56	SCREW	1		
3	506 40 60-01	SPRING	1		
4	506 40 63-02	SPRAY GUARD	1		
5	740 42 05-00	O-RING	2		
6	506 40 37-01	BUSHING	1		
7	732 21 14-01	LOCK NUT	1		
8	525 73 98-01	HOLDER	1		
9	544 03 21-01	SPRAY GUARD	1		
10	503 21 53-16	SCREW	2		
11	544 03 22-01	PLATE	1		
12	544 03 92-01	BUSHING	2		
13	510 05 66-01	SPRAY GUARD ASSY	1	Incl. 14 - 21	
14	510 00 72-01	SPRAY GUARD UPPER	1		
15	510 00 73-01	GUIDE PIECE	1		
16	503 21 46-01	SCREW	2		
17	734 48 80-01	WASHER	2		
18	506 26 22-02	WHEEL	2		
19	510 20 24-01	BAND	1		
20	510 20 20-01	WASHER	2		
21	503 21 27-16	SCREW	4		
22	522 03 81-01	LABEL	1		

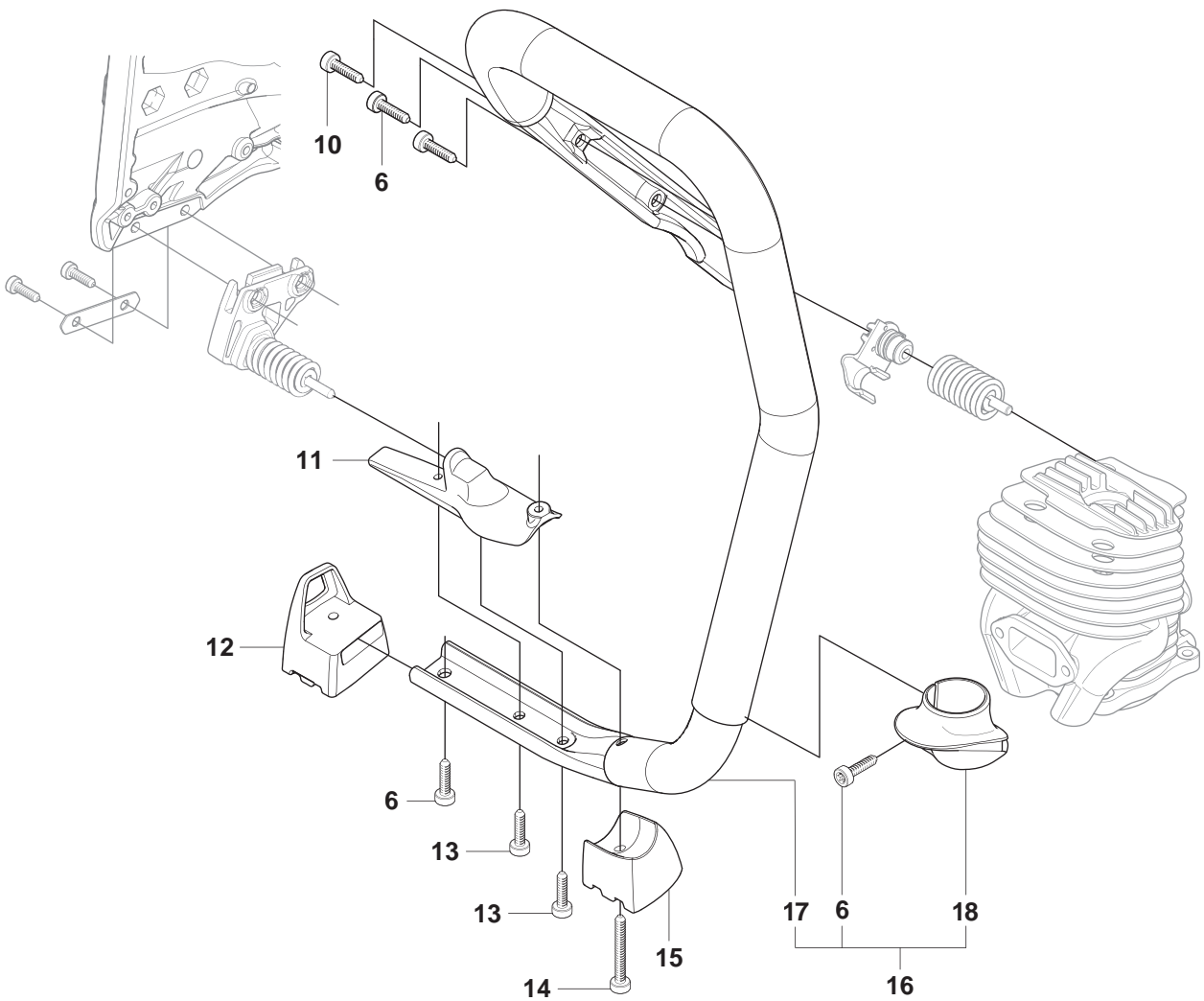
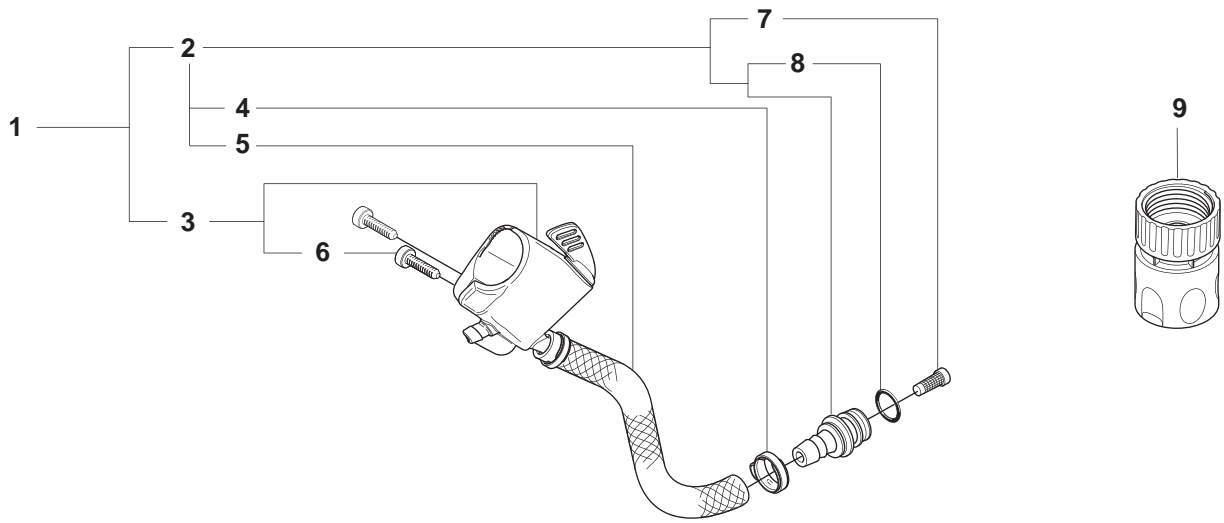
H**K760 Cut-n-Break**

Page H**K760 Cut-N-Break**

Pos.	Part No.	Description	Quantity	Notes	New Part
1	505 09 55-03	HOSE KIT	1	Incl. 2 - 3	
2	575 51 62-01	HOSE ASSY	1	Incl. 4 - 5, 7 - 8	
3	506 38 60-05	VALVE ASSY	1	Incl. 7	
4	506 49 87-02	HOSE CLAMP	1		
5	575 30 31-01	HOSE ASSY	1		
6	503 21 54-20	SCREW	8		
7	506 29 88-01	FILTER	1		
8	505 10 35-01	O-RING	1		
9	503 26 60-03	COUPLING	1	USA, Canada	
9	503 26 60-04	COUPLING	1		
10	544 06 12-01	SCREW	3		
11	506 37 72-02	SPRING RETAINER	1		
12	522 83 23-01	GROUND SUPPORT	1		
13	503 21 53-10	SCREW	2		
14	503 21 53-40	SCREW	1		
15	522 83 24-01	GROUND SUPPORT	1		
16	575 35 13-01	HANDLE	1	Incl. 6, 17 - 18	
17	506 37 11-03	FRONT HANDLE	1		
18	506 38 71-02	STOP	1		

J

K760 Cut-n-Break

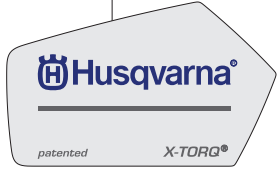
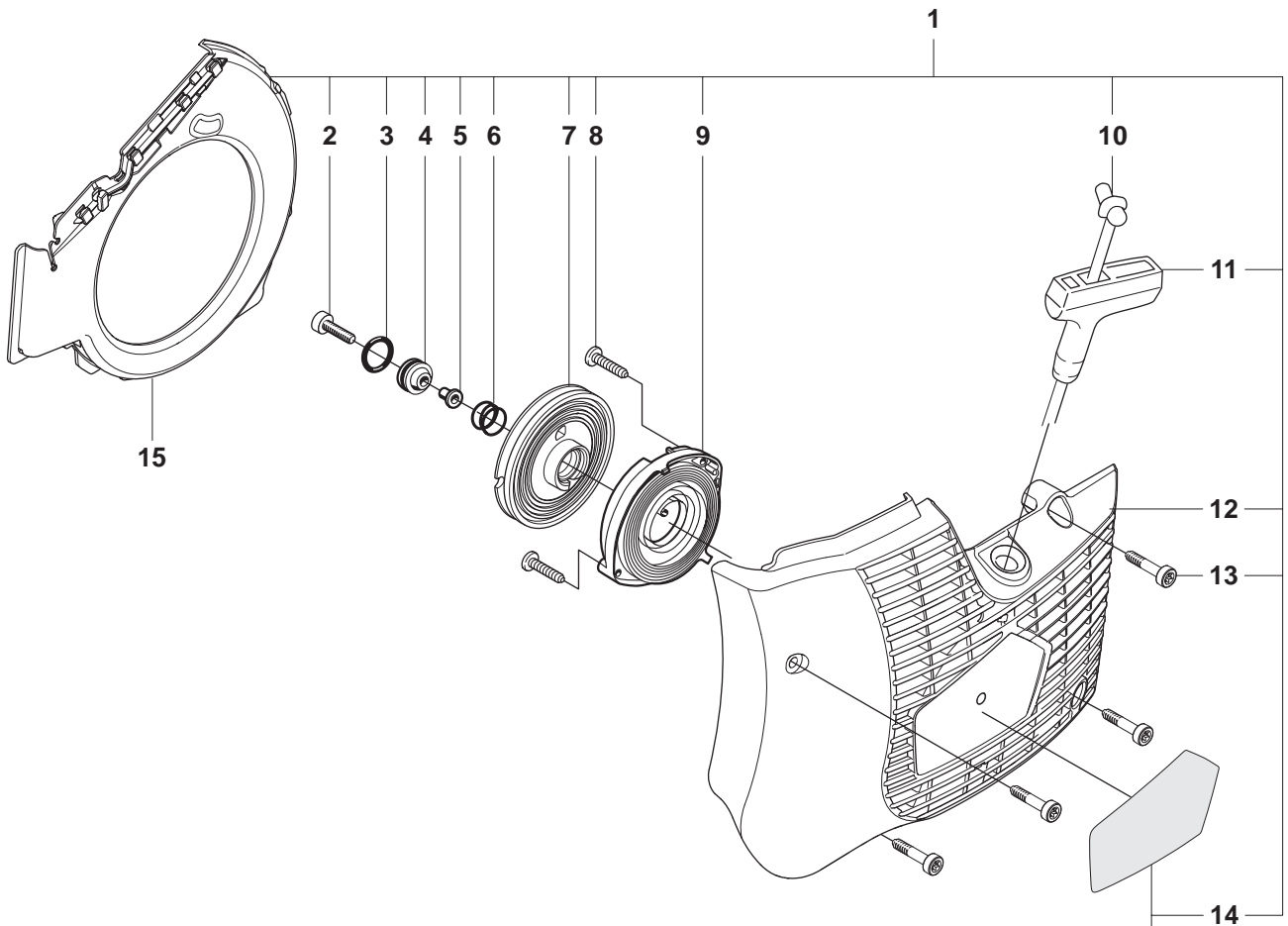

Page J**K760 Cut-N-Break**

Pos.	Part No.	Description	Quantity	Notes	New Part
1	574 36 20-01	STARTER	1	Incl. 2 - 15	
2	510 26 92-22	SCREW	1		
3	740 43 13-00	O-RING	1		
4	510 00 08-01	SEALING HOLDER	1		
5	506 26 31-01	SPACING SLEEVE	1		
6	506 25 30-01	COMPRESSION SPRING	1		
7	506 25 81-02	STARTER PULLEY	1		
8	503 21 28-10	SCREW	2		
9	506 25 89-01	RECOIL SPRING	1		
10	506 33 56-15	STARTER CORD	1		
10	506 33 56-50	STARTER CORD	1	50 m	
11	503 12 79-01	STARTER HANDLE	1		
12	525 44 60-01	STARTER COVER	1		
13	501 98 10-20	SCREW	4		
14	525 57 11-01	LABEL	1		
15	544 38 39-01	AIR CONDUCTOR	1		

K K760 Cut-n-Break

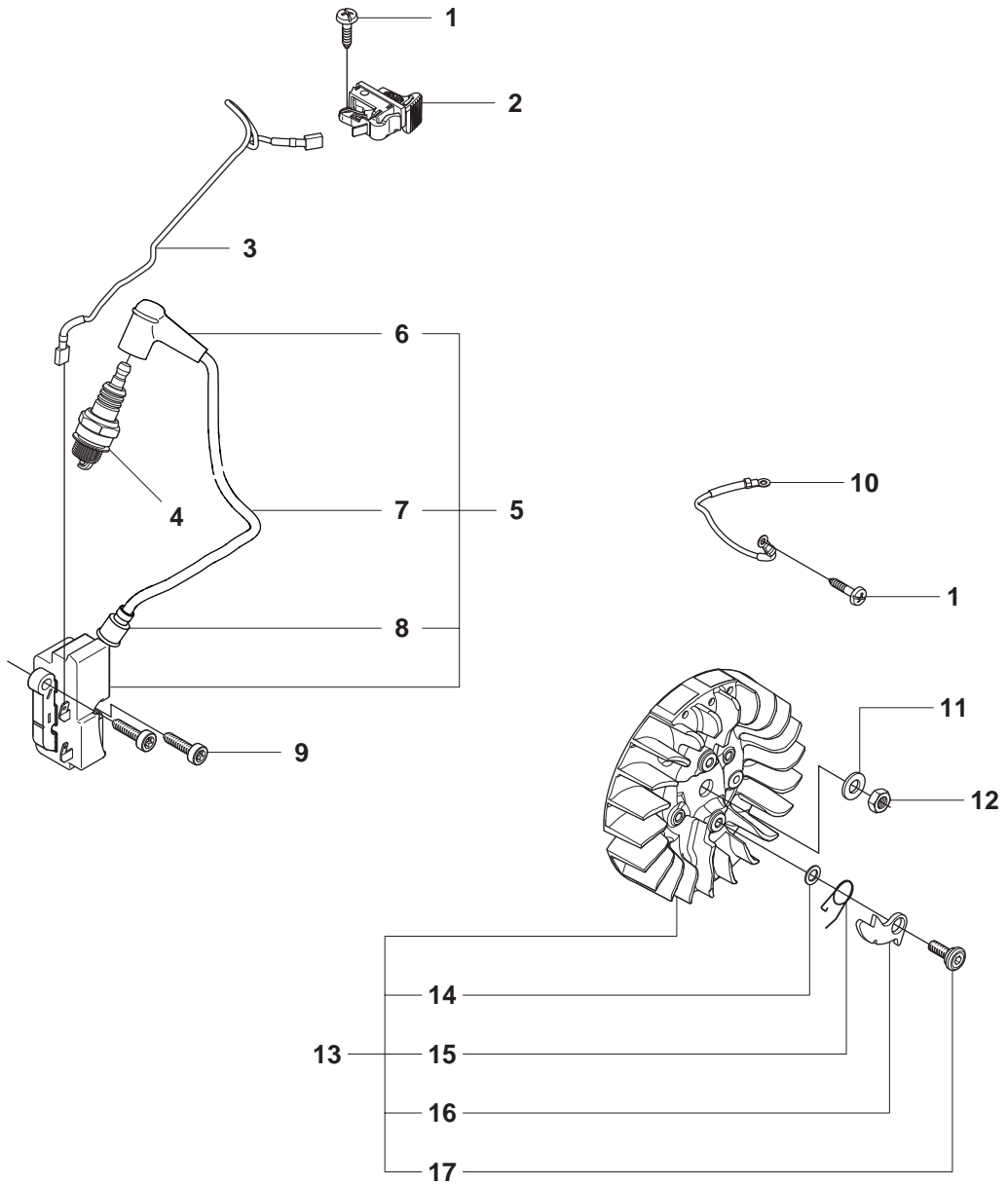

Page K**K760 Cut-N-Break**

Pos.	Part No.	Description	Quantity	Notes	New Part
1	503 21 28-10	SCREW	2		
2	506 31 86-02	STOP SWITCH	1		
3	506 37 84-02	CABLE	1		
4	503 23 51-09	SPARK PLUG	1	RCJ 6 Y	
5	510 11 56-02	IGNITION MODULE	1	Incl. 6 - 8	
6	501 48 54-02	SPARK PLUG CAP	1		
7	506 38 78-34	IGNITION CABLE	1		
8	505 27 75-16	ISOLERHATT	1		
9	503 21 53-20	SCREW	2		
10	506 37 85-01	CABLE	1		
11	503 23 01-01	WASHER STEEL	1		
12	503 22 10-11	NUT	1		
13	501 37 56-01	FLYWHEEL	1	Incl. 14 - 17	
14	503 23 00-42	WASHER STEEL	2		
15	501 63 48-01	SPRING	2		
16	501 67 32-03	PAWL	2		
17	506 00 69-01	SCREW	2		

L K760 Cut-n-Break

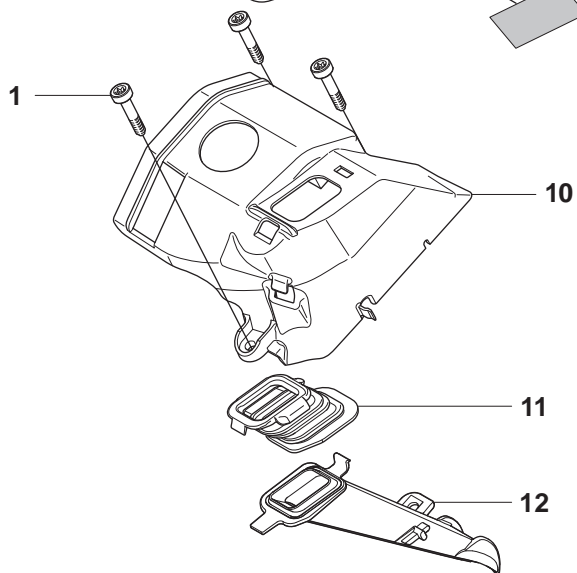
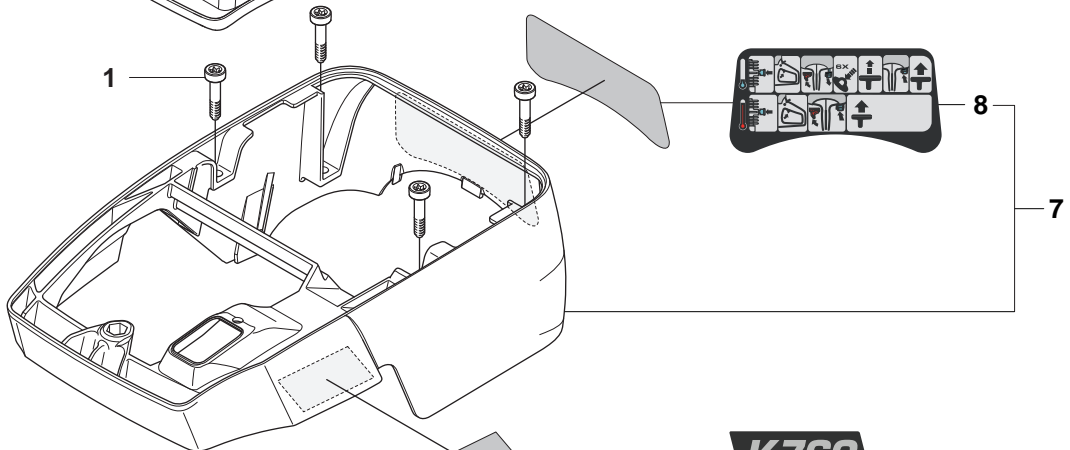
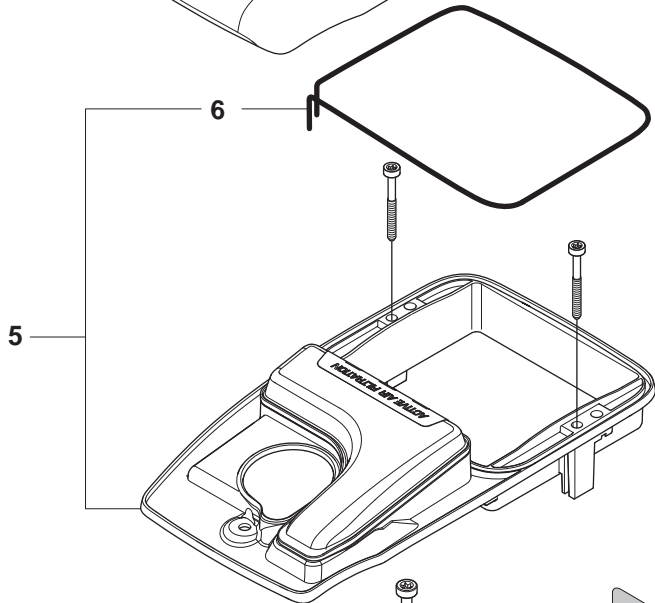
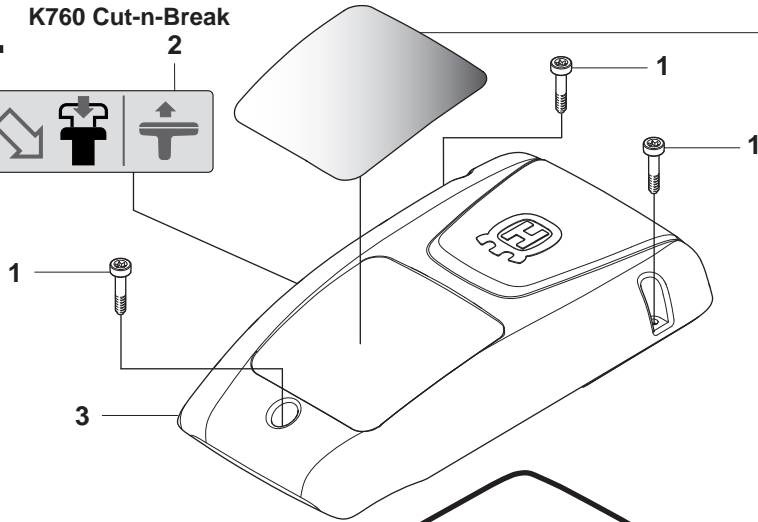
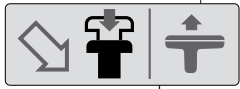

⚠ WARNING ⚠
⚠ Cutters can be dangerous! ⚠

For safe operations
 operators in
 • Only persons who have
 been instructed in the use
 of this cutter and who are
 familiar with all safety
 procedures in the Operator's Manual shall operate the cutter.
 Operators can use special service tools.
 • Use only designed or approved cutting equipment approved for
 intended cutting on high speed cutters.
 • Use personal protective equipment as outlined in the Operator's
 Manual. Pay special attention to eye protection and breathing
 mask.
 • Operation of this equipment may create sparks that can start
 fires around dry vegetation. A spark arrester may be required.
 The operator should consult local fire agencies for laws or
 regulations related to fire prevention.

follow all safety
 operators manual.

SAFETY PRECAUTIONS:
 • ALWAYS WEAR EYE PROTECTION AND BREATHING MASK.
 • NEVER OPERATE THE CUTTER WITHOUT THE GUARD.
 • NEVER OPERATE THE CUTTER WITHOUT THE GUARD.
 • NEVER OPERATE THE CUTTER WITHOUT THE GUARD.
 • NEVER OPERATE THE CUTTER WITHOUT THE GUARD.

©2020/2021 CONSTRUCTION PRODUCTS, WATSON

⚠ WARNING ⚠

SAFETY PRECAUTIONS:
 • ALWAYS WEAR EYE PROTECTION AND BREATHING MASK.
 • NEVER OPERATE THE CUTTER WITHOUT THE GUARD.
 • NEVER OPERATE THE CUTTER WITHOUT THE GUARD.
 • NEVER OPERATE THE CUTTER WITHOUT THE GUARD.
 • NEVER OPERATE THE CUTTER WITHOUT THE GUARD.

©2020/2021 CONSTRUCTION PRODUCTS, WATSON

K760
 Cut-n-Break

Page L
K760 Cut-N-Break

Pos.	Part No.	Description	Quantity	Notes	New Part
1	503 21 53-21	SCREW	10		
2	525 76 35-02	DECAL	1		
3	525 44 43-01	FILTER COVER	1		
4	574 23 14-01	DECAL	1	EPA USA	
4	574 23 14-02	DECAL	1	CE, EPA Canada	
5	574 36 21-01	FILTER HOLDER ASSY	1	Incl. 6	
6	525 61 70-02	SEALING	1		
7	506 39 84-05	CYLINDER COVER ASSY	1	Incl. 8	
8	544 89 09-02	LABEL	1		
9	574 23 16-01	DECAL	1		
9	574 23 16-02	DECAL	1	Rescue	
9	574 23 16-03	DECAL	1	Oil Guard	
10	506 37 02-01	COVER	1		
11	506 37 04-01	BELLOWS	1		
12	525 58 43-01	AIR NOZZLE	1		

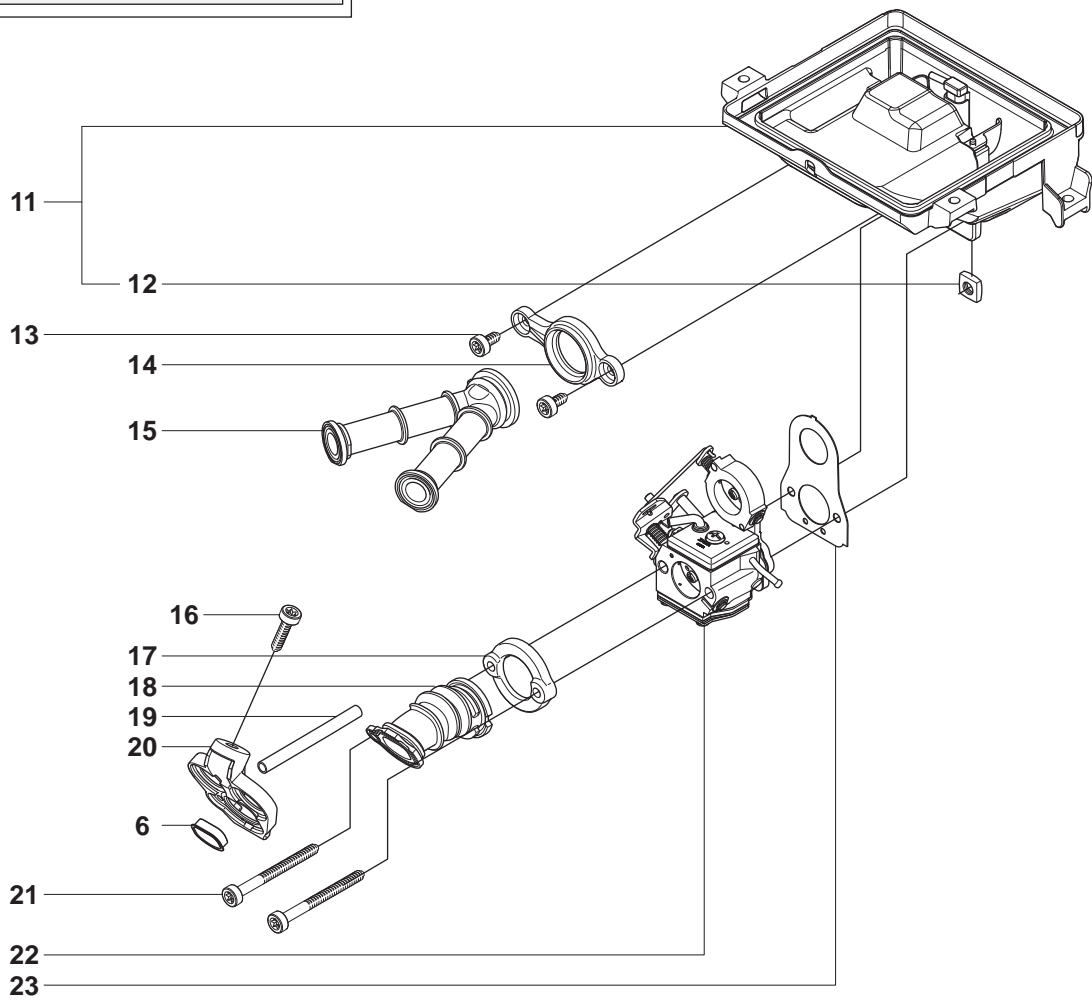
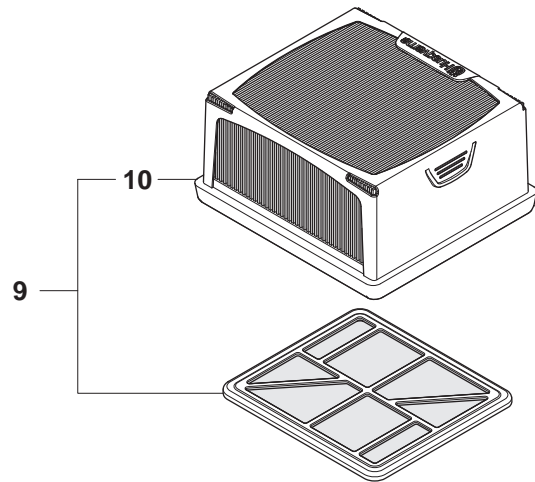
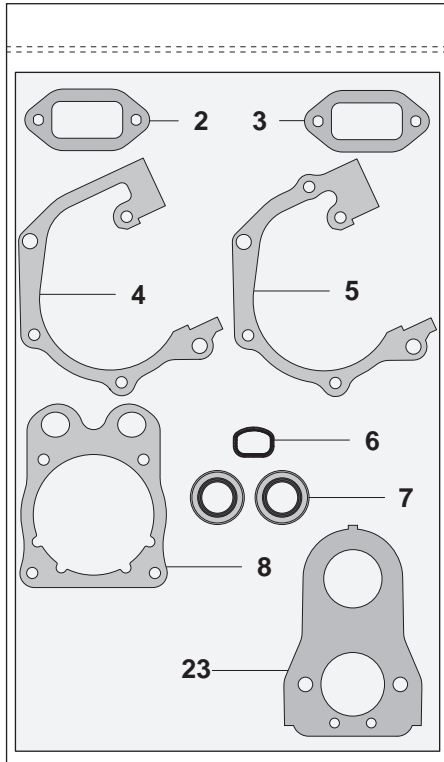
M**K760 Cut-n-Break**

Page M**K760 Cut-N-Break**

Pos.	Part No.	Description	Quantity	Notes	New Part
1	506 38 53-05	GASKET KIT	1	Incl. 2 - 8, 23	
2	506 41 23-01	GASKET	1		
3	506 37 69-02	GASKET MUFFLER	1		
4	506 37 70-02	GASKET CRANKCASE	1		
5	506 37 70-03	GASKET CRANKCASE	1		
6	544 21 93-02	INSERT	1		
7	503 26 02-04	SEALING RING	2		
8	506 37 67-01	CYLINDER BASE GASKET	1		
9	574 36 23-01	FILTER	1	Incl. 10	
10	525 47 06-01	AIR FILTER PAPER	1		
11	575 35 40-01	CARBURETTOR BRACKET	1	Incl. 12	
12	503 22 65-04	NUT	4		
13	503 21 53-10	SCREW	2		
14	506 37 06-01	FLANGE INLET PIPE	1		
15	506 36 98-01	INLET PIPE	1		
16	503 21 53-20	SCREW	1		
17	506 37 05-01	FLANGE INLET PIPE	1		
18	506 36 97-01	INLET PIPE	1		
19	503 40 06-09	IMPULSE HOSE	1		
20	544 35 26-01	PLATE	1		
21	503 21 53-56	SCREW	2		
22	510 18 12-02	CARBURETTOR	1	Zama C3-EL43A	
23	506 37 68-03	GASKET CARBURETTOR	1		

N K760 Cut-n-Break

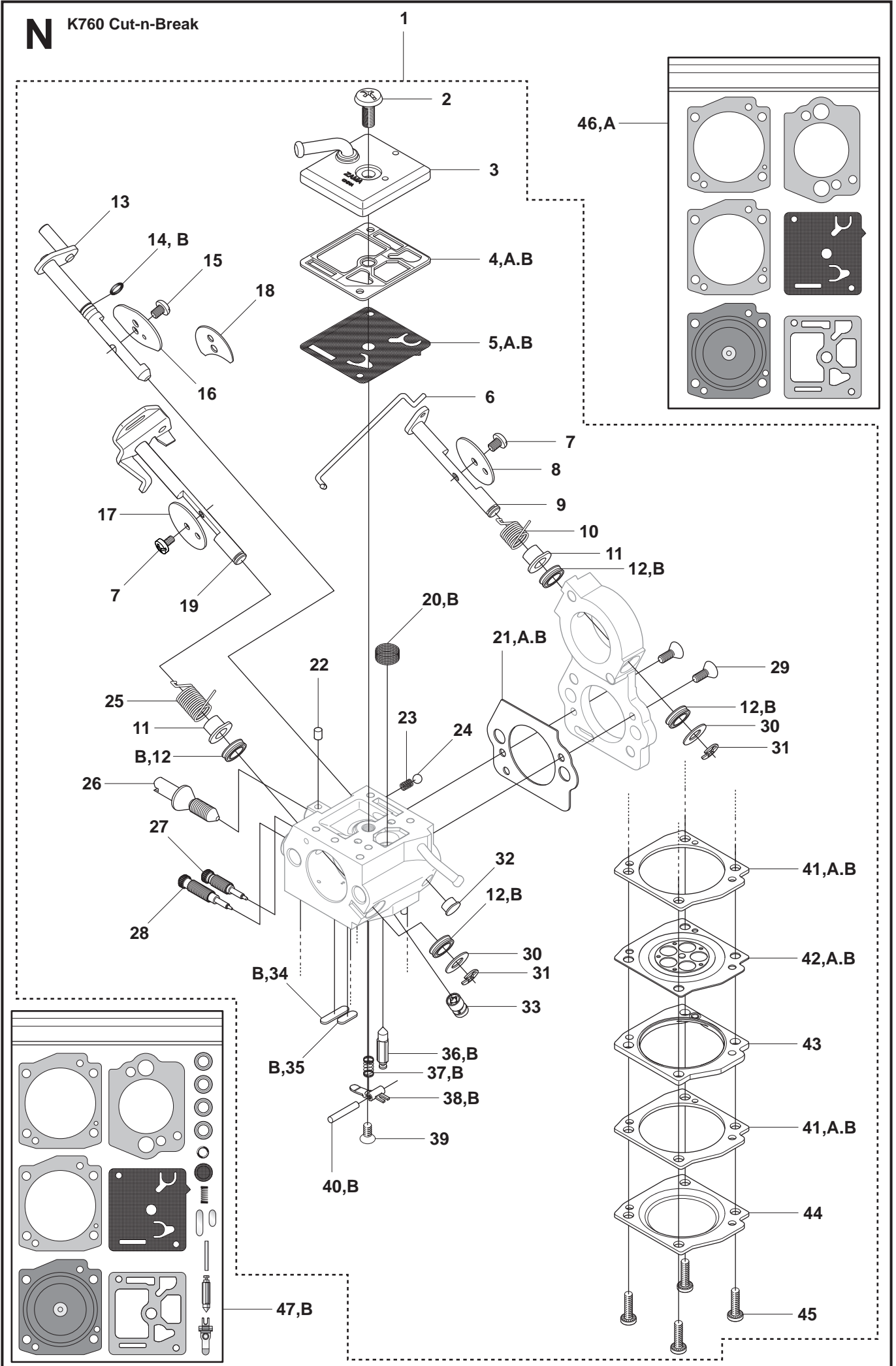

Page N

K760 Cut-N-Break

Pos.	Part No.	Description	Quantity	Notes	New Part
1	510 18 12-02	CARBURETTOR	1	Zama C3-EL43A, Incl. 2 - 43	
2	503 47 96-01	SCREW	1		
3	544 83 64-01	PUMP COVER	1		
4	503 61 66-01	GASKET PUMP	1		
5	506 39 60-01	DIAPHRAGM PUMP	1		
6	506 39 65-01	ROD	1		
7	544 08 22-01	SCREW	2		
9	506 39 71-01	SHAFT ASSY	1		
10	506 39 75-01	SPRING	1		
11	506 39 54-01	COLLAR	2		
12	506 39 64-01	QUAD RING	4		
13	506 39 73-01	SHAFT ASSY CHOKE	1		
14	506 39 90-01	O-RING	1		
15	503 48 18-01	SCREW	1		
16	506 39 78-01	VALVE	1		
17	537 17 70-01	VALVE	1		
18	522 60 75-01	VALVE	1	Japan only	
19	506 39 74-01	SHAFT ASSY	1		
20	503 53 57-01	STRAINER	1		
21	506 39 58-01	GASKET	1		
22	503 48 11-01	PIECE	1		
23	537 01 26-01	SPRING	1		
24	537 01 25-01	BALL	1		
25	544 83 65-01	SPRING	1		
26	506 39 72-01	SCREW	1		
27	506 39 70-01	SCREW	1		
28	506 39 69-01	SCREW	1		
29	537 38 51-01	SCREW	2		
30	506 39 79-01	WASHER	2		
31	537 38 52-01	E-CLIP	2		
32	506 39 91-01	PLUG	1		
33	506 39 61-01	NOZZLE ASSY	1		
34	503 53 56-01	PLUG WELCH	1		
35	537 17 78-01	PLUG	1		
36	537 17 62-01	VALVE	1		
37	575 44 13-01	SPRING	1		
38	537 17 64-01	LEVER	1		
39	544 08 21-01	SCREW	1		
40	503 48 00-01	PIN RETAINING SCREW	1		
41	506 39 62-01	GASKET	2		
42	506 39 57-01	DIAPHRAGM ASSY	1		
43	506 39 55-01	COVER	1		
44	506 39 56-01	COVER	1		
45	506 39 66-01	SCREW	4		
46	506 40 99-01	GASKET KIT	1	Incl. 4-5, 21, 41, 42	
47	506 41 00-03	GASKET KIT CARB	1	Incl. 4-5, 12, 14, 20, 21, 34-38, 40-42	

P K760 Cut-n-Break
Accessories

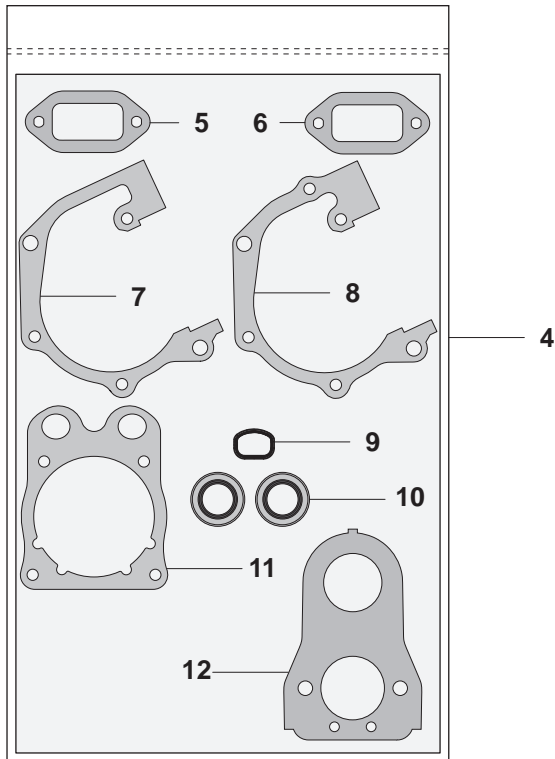
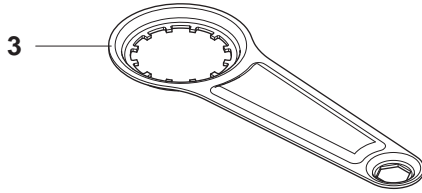
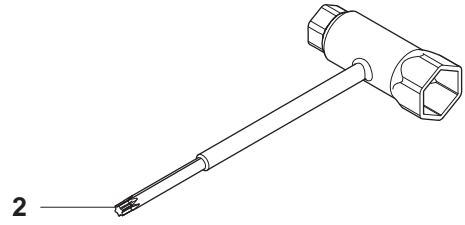
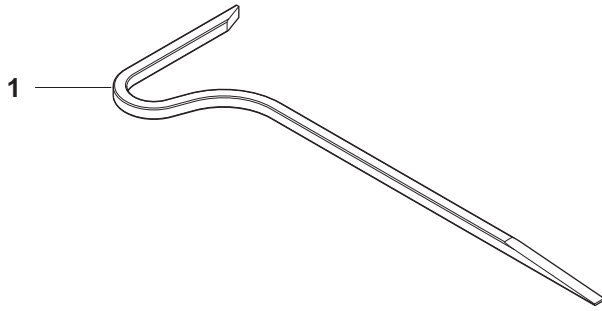

Page P**K760 Cut-N-Break**

Pos.	Part No.	Description	Quantity	Notes	New Part
1	544 17 80-02	TOOL	1		
2	506 38 26-01	COMBINATION TOOL	1		
3	544 17 81-01	PULLER	1		
4	506 38 53-05	GASKET KIT	1	Incl. 5 - 12	
5	506 41 23-01	GASKET	1		
6	506 37 69-02	GASKET MUFFLER	1		
7	506 37 70-02	GASKET CRANKCASE	1		
8	506 37 70-03	GASKET CRANKCASE	1		
9	544 21 93-02	INSERT	1		
10	503 26 02-04	SEALING RING	2		
11	506 37 67-01	CYLINDER BASE GASKET	1		
12	506 37 68-03	GASKET CARBURETTOR	1		