



# Benner-Nawman, Inc.

3450 Sabin Brown Road • Wickenburg, AZ 85390

(800) 992-3833 • (928) 684-2813 • mail@bnproducts.com

Fax: (928) 684-7041

www.bnrebartools.com

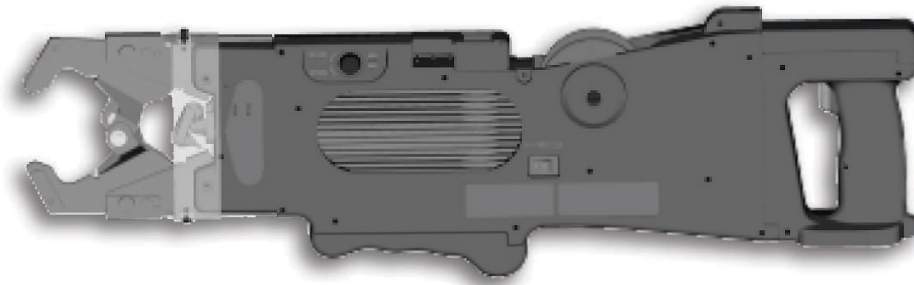

BN-Tier™  
(BNT-64)

## Cordless Rebar Tying Tool Instruction Manual

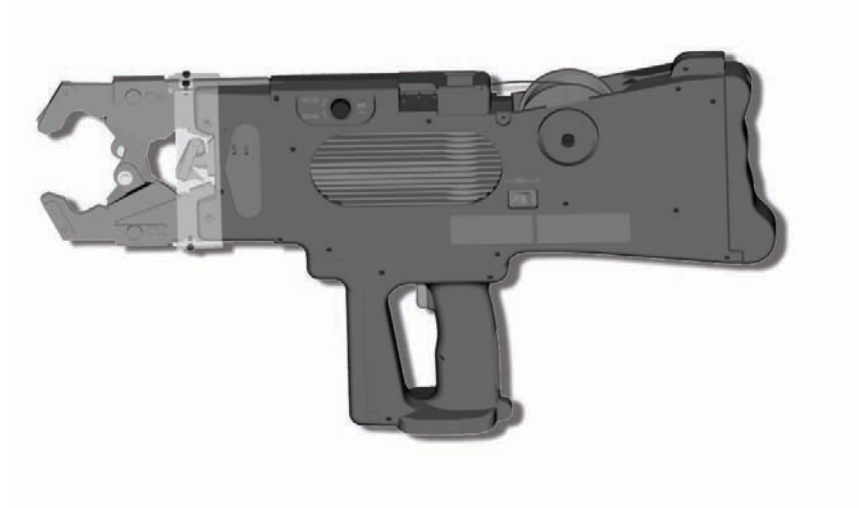

# Contents of This Manual

	Page		Page
1 General safety rules	3	2. Method of Operating the BN-Tier™	7
1.2 Work area	3	2.2 Wire Spool Replacement Procedure	8
1.3 Electrical safety	3	2.3 Battery Pack Replacement Procedure	8
1.4 Personal safety	3	2.4 Changing the Position of the Handle.	8
1.5 Tool use and care	3	2.5 General Cautions on Operating	9
1.6 Service	4	2.6 How to Use the BN-Tier™ Efficiently	9
Safety Standards and Symbols	4	Part 4 Battery Charger	9
Contents of Your Package	4	3. Battery Pack Charging Procedure	9
Part 1 Description	4	3.1 Power Source for Battery Charger	9
1. Outline of the BN-Tier™	4	3.3 Battery Pack Charging Procedure	10
1.1 Function of the BN-Tier™	4	3.4 General Cautions on Battery Charger	10
1.2 Application of the BN-Tier™	4	4. Maintenance of the Battery Charger	10
Application Scale	5	4.1 Daily Inspection of the Battery Charger	10
1.3 Rules of Use and Storage	5	4.2 After Sales Service of the Battery Charger	10
1.4 Names of the Main Unit Components	5	Part 4 Troubleshooting	11
1.5 Specification of the Main Unit	5	• BN-TIER #BNT-64 VERTICAL WORK	
1. Check Items Prior to Operation	7	PARTS BREAKDOWN	14
1.2 Maintenance of the Main Unit	7	• BN-TIER #BNT-64 HORIZONTAL	
1.3 Removing and Replacing WireGuides	7	WORK PARTS BREAKDOWN	15
		Parts List	16



# Instruction Manual

## Purpose of this manual

This manual is intended to provide users with correct knowledge and the procedures for operation, maintenance and inspection of the BN-Tier™, an auto wire tying tool for reinforcing bars.

Erroneous use of this tool may possibly lead to a serious accident. Therefore, always read this instruction manual before using the tool to familiarize yourself with its correct usage, operating method, warning, etc.

## Safety Instruction

### SAVE THESE INSTRUCTIONS

## 1 General safety rules

1.1 **Warning!** Read and understand all instructions. Failure to follow all instructions listed here, may result in electric shock, fire and/or serious personal injury.

### 1.2 Work area

1.2.1 Keep your work area clean and well lit. Cluttered benches and dark areas invite accidents.

1.2.2 Do not operate power tools in explosive atmospheres, such as in the presence of flammable liquid, gases, or dust. Power tools create sparks which may ignite the dust or fumes.

1.2.3 Keep bystanders, children, and visitors away while operating a power tool. Distractions can cause loss of control.

### 1.3 Electrical safety

1.3.1 **Do not abuse the cord. Never use the cord to carry the tool. Keep cord away from heat, oil, sharp edges, or moving parts. Replace damaged cords immediately.** Damaged cords may create a fire.

1.3.2 **A battery operated tool with integral batteries or a separate battery pack must be recharged only with the specified charger for the battery.** A charger that may be suitable for one type of battery may create a risk of fire when used with another battery.

1.3.3 **Use battery operated tool only with specifically designate battery pack.** Use of any other batteries may create a risk of fire.

1.3.4 The battery charger is fully automatic. Please refer to charging instructions.

1.3.5 Only use and charge battery type supplied with the battery charger. Do not use the charger for any other type of battery.

## 1.4 Personal safety

1.4.1 **Stay alert, watch what you are doing, and use common sense when operating a power tool. Do not use tool while tired or under the influence of drugs, alcohol, or medication.** A moment of inattention while operating power tools may result in serious personal injury.

1.4.2 **Dress properly. Do not wear loose clothing or jewelry. Contain loose hair. Keep your hair, clothing, and gloves away from moving parts.** Loose clothes, jewelry, or long hair can be caught in moving parts.

1.4.3 **Avoid accidental starting. Be sure switch is in the locked or off position before inserting battery pack.** Carrying tools with your finger on the switch or inserting the battery pack into a tool with the switch on invites accidents.

1.4.4 **Remove adjusting keys or wrenches before turning the tool on.** A wrench or key that is left attached to a rotating part of the tool may result in personal injury.

1.4.5 **Do not overreach. Keep proper footing and balance at all times.** Proper footing and balance enable better control of the tool in unexpected situation.

1.4.6 **Use safety equipment. Always wear eye protection.** Dust mask, non-skid safety shoes, hard hat, or hearing protection must be used for appropriate conditions.

1.4.7 This tool is not intended for use by young children or infirm persons or workers that have not been supervised in the use of the product. All users should be supervised by a responsible person to ensure that they can use the tool safely.

1.4.8 Young children should be supervised to ensure that they do not play with this tool.

1.4.9 If the power supply cord is damaged it must be replaced by the manufacturer, its service agent or similarly qualified person in order to avoid a safety hazard.

## 1.5 Tool use and care

1.5.1 **Use clamps or other practical way to secure and support the work piece to a stable platform.** Holding the work by hand or against your body is unstable and may lead to loss of control.

1.5.2 **Do not force tool. Use the correct tool for your application.** The correct tool will do the job better and safer at the rate for which it is designed.

1.5.3 **Do not use tool if switch does not turn on or off.** A tool cannot be controlled with the switch is dangerous and must be repaired.

1.5.4 **Disconnect battery pack from tool or place the switch in the locked or off position before making any adjustment, changing accessories, or storing the tool.** Such preventive safety measures reduce the risk of starting the tool accidentally.

1.5.5 **Store idle tools out of reach of children and other untrained persons.** Tools are dangerous in the hand.

1.5.6 When battery pack is not in use, keep it away from other metal objects like: paper clips, coins, keys, nails, screws, or other small metal objects that can make a connection from one terminal to another. Shorting the battery terminals together may cause sparks, burns, or a fire.

1.5.7 Maintain tools with care. Keep cutting tools sharp and clean. Properly maintained tools with sharp cutting edge are less likely to bind and are easier to control.

1.5.8 Check for misalignment or binding of moving parts, breakage of parts, and any other condition that may affect the tool's operation. If damaged, have the tool serviced before using. Many accessories are caused by poorly maintained tools.

1.5.9 Use only accessories that are recommended by the manufacturer for your model. Accessories that may be suitable for one tool may create a risk of injury when used on another tool.

## 1.6 Service

1.6.1 Tool service must be performed only qualified repair personnel. Service or maintenance performed by unqualified personnel may result in a risk injury.

1.6.2 When servicing a tool, use only identical replacement parts. Follow instructions in the Maintenance section of this manual. Use of unauthorized parts or failure to follow Maintenance Instructions may create a risk of shock or injury.

## Safety Standards and Symbols

This manual describes warning by classifying them into three levels of DANGER, WARNING, and CAUTION according to the level of seriousness. Make sure that you fully understand these warning before using the Bar-tier.



**! DANGER !**

If a danger warning is neglected, it could result in death or serious injury.



**! WARNING !**

If a warning is neglected, a hazard is presumed to exist that may result in death or serious injury.



**! CAUTION !**

If a warning is neglected, a latent hazard is presumed to exist that may result in non-serious damage necessitating financial compensation.

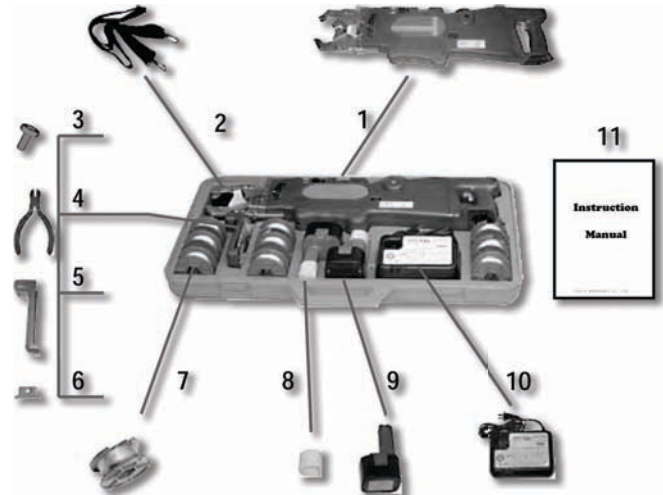

## Contents of Your Package

Upon purchasing the BN-Tier™, open the tool pack and check the contents for the following:

- |                       |                                    |
|-----------------------|------------------------------------|
| 1. Main unit (1)      | 7. Wire spools -18 gauge (10)      |
| 2. Shoulder Strap (1) | 8. Battery terminal cap (2)        |
| 3. Screw (1)          | 9. BN-12V Ni-Cad battery pack (2)  |
| 4. Nipper (1)         | 10. BN-12VCHGR battery charger (1) |
| 5. Handle cap (1)     | 11. Instruction manual (1)         |
| 6. Inlay (1)          |                                    |

## Part 1 Description

### 1. Outline of the BN-Tier™

This section describes the functions, applications, service environment and other aspects of the BN-Tier™.

#### 1.1 Function of the BN-Tier™

The BN-Tier™ is a power tool developed for streamlined, one-action application for tying reinforcing bars that constitute the basis of foundation work on construction sites, floors, walls, ceilings and other reinforcing bar concrete work, reinforcing bar concrete work in the reclamation sites, bridge piers, tunnels and other civil engineering works, and works in various concrete product manufacturing plants.

#### 1.2 Application of the BN-Tier™

Actual areas of application of the BN-Tier™ by type of work, material and method of use are as follows. The type of work the BN-Tier™ can be applied to is limited to the re-bar setting for concrete placing on construction sites for, reclamation, bridge pier and tunnel construction works, etc. The type of material the BN-Tier™ can be applied to is limited to reinforcing bars, PC reinforcing steel bars, hereinafter referred to as PC steel bars, PC steel and wire. The maximum diameter of this tool is (2) each 32mm or (#10) Rebar with #64 wire guide installed.

## Application Scale

Rebar tying size combinations are:

- a+b is less than or equivalent to
- #4 + #5 or 29 mm (#26) Wire Guide
- #6 + #6 or 38 mm (#32) Wire Guide
- #8 + #8 or 51 mm (#51) Wire Guide
- #10 + #10 or 64 mm (#64) Wire Guide
- And clearance below rebar required
- a+b+c is greater than
- 1.87" or 48 mm (#26) Wire Guide
- 2.18" or 56 mm (#32) Wire Guide
- 2.85" or 73 mm (#51) Wire Guide
- 3.27" or 84 mm (#64) Wire Guide

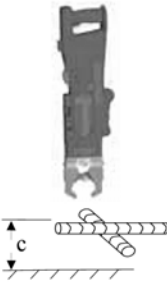

1.2.2 The BN-TIER is designed to lock and disable the tying switch unless it holds the reinforcing bars completely within the wire guides, or working condition can not reach the requirements (1.2.1), use the BN-TIER after placing spacers (wood, pipe, rebar chairs, etc.) under the reinforcing bars by lifting them to the required height as shown in the figure using a bar or other tool.

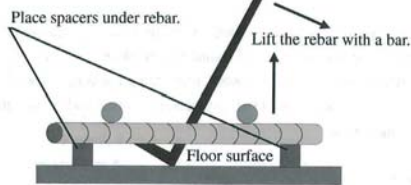

## 1.3 Rules of Use and Storage

To use the BN-Tier™ to its fullest performance, the user is required to be fully conversant with wire spool and battery pack replacement, recharging, troubleshooting and storage procedures upon completion of work.

Consequently, the company or manager in charge is recommended to formulate rules for BN-Tier™ operation and storage, appoint operators and provide them with the necessary training.

Inexperienced operators must be instructed to read this manual

before using the BN-Tier™. When formulating BN-Tier™ operation rules, the following must be reflected in the contents:

No smoking should be strictly observed during work.

## 1.4 Names of the Main Unit Components

The picture above the names of respective components of the BN-Tier™ main unit (see picture below).

## 1.5 Specification of the Main Unit

The BN-Tier™ is a wire tying tool based on the double layer tying method. The specifications of the main unit are as follows.

Wire feeding method	Replaceable spool
Tying wire (dedicated wire)	Special steel wire 1.00 mmDia. With plated finish
Number of continuous tying with one wire spool	120 ~ 200 times/spool
Tying times / Battery pack	About 450 times
Diameter combinations	Total Diameter is 12/8(32 G-GUIDE) inches
Dimensions	180×80×660 mm or 290×80×580 mm
Main unit weight (including one battery pack)	3.8kg (include Battery pack and Wire spool)
Service temperature	0 to 50°C (32 to 122°F)

## 1.6 Specifications of the Battery Pack

Model No.	BN-12VCAD
Max. condensed voltage	12V
Charging time	Approx.30 min
Service temperature	0 to 50°C (32 to 122°F)
Service Humidity	90% or under (non-condensing)
Storage Humidity	Same as above



**! DANGER !** May cause explosion, fire or toxic gas generation. Ignoring this warning may cause death or serious injury. Do not dispose of the battery pack in fire or dump in water or other wet place.

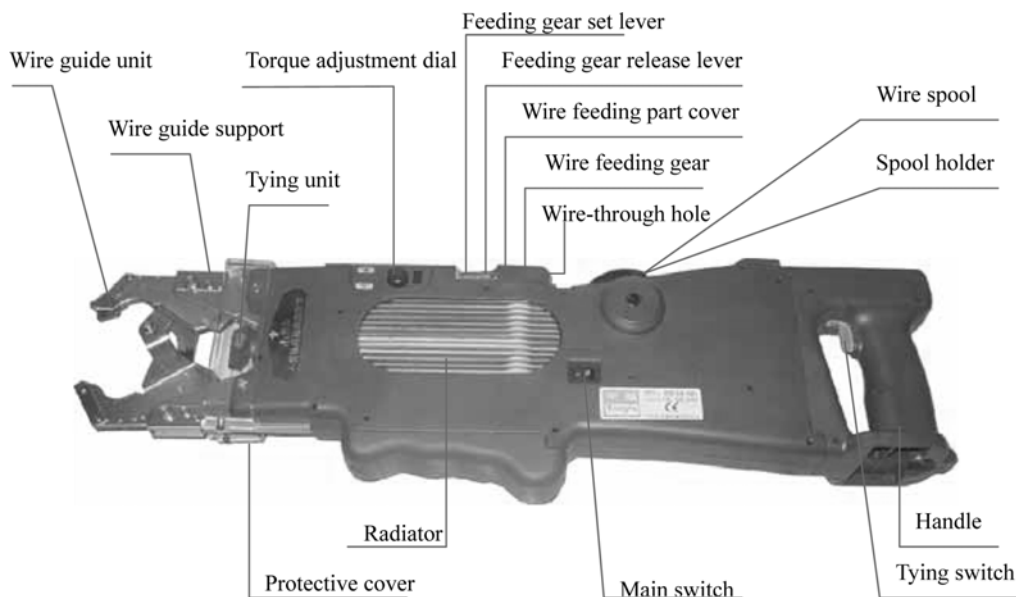



Company Name	Benner-Nawman, Inc.
Model Number	BN-Tier #BNT-64
Max. Tying Capacity	#10 (32mm) x #10 (32mm) with the optional #64 wire guide
Tool Weight	8.4 lbs (3.8 kg) with battery and wire spool
Shipping Weight	BN-Tier with std. equip. 27 lbs (12.25 kg)
"Tool Dimensions H" x W" x L" (mm)	7.02" x 3.12" x 25.74" (180 x 80 x 660) for horizontal work or converts to 11.31" x 3.12" x 22.62" (290 x 80 x 580) for vertical work
Number of Parts	75
Tying Speed	1.6 seconds/tie
Tie Wraps/Wire Size	(2) wraps of 18 gauge or 1.0mm
Wire Spool Length	(148 ft) 45 m/coil
Wire Types	Galvanized Wire only
Ties Per Coil	120 to 200
Wire Spools Carton/	40 spools per carton
Shipping Weight	29 lbs. (13 kg) per carton
Ties Per Battery Charge	750 ties/charge (4-5 wire spools)
Torque Adjustment	Yes, 0-9 (increases wire tightness)
BN-Tier Standard Equipment Tier handle is easily changed for horizontal or vertical work. #32 wire guide installed (ties max. #5 and #6 rebar)	Plastic molded carrying case BN-Tier with #32 wire guide installed 2 Batteries and a charger Ergonomic shoulder strap 10 spools of galvanized wire Instruction Manual
Optional Wire Guides Using the proper size wire guide increases wire usage and tying speed	#26 wire guide (ties max. #3 and #4 rebar) #51 wire guide (ties max. #8 and #8 rebar) #64 wire guide (ties max. #10 and #10 rebar)
Battery Type (#BN-12VCad)	Ni-Cd
Battery Voltage	DC 12V
Recharging Time	Approx. 30 minutes
Battery Charger (#BN-12VChgr)	110-240 VAC, 50/60Hz
Country of Origin	China
Operating Humidity	90% or under
Operating Temperature	0 to 50 degrees C (32 to 122 degrees F)
Warranty Period	One Year Limited

# Part 2 Operation

## 1. Check Items Prior to Operation

Prior to operating the BN-Tier™, a check must be made of the working environment, tying wire and battery pack. The following describe the respective check items.

### 1.1 Checking and Preparation of Working Environment

Check the following before using the BN-Tier™. Always observe the instructions and prohibited items.

#### 1.1.1 Checking of weather conditions

Before using the BN-Tier™, always observe the instructions and prohibited items if any of the following weather conditions occur at the work site.

##### (1) Do not use in the rain or snow

The BN-Tier™ is not a waterproof power tool. If it becomes wet, the power source system may become faulty or the operator may get an electric shock. Therefore, when it is raining or snowing, never operate the BN-Tier™ outdoors, on top of buildings or under roofs where rain or snow enters freely.



**! DANGER**

Electric shock hazard. Ignoring this warning may lead to death or serious injury. Do not use this tool in a place possibly splashed with water or watery place involving the danger of soaking in water.

##### (2) Do not use under high temperature and humidity or extremely cold temperature conditions

The BN-Tier™ is designed for use under an allowable environmental temperature of 0 to 50°C (32°-122°F). Operation at higher temperature may cause the BN-Tier™ main unit to overheat or the battery pack to become faulty. Operation at high temperature with high humidity may cause the BN-Tier™ to fail due to condensation. Therefore, never operate the BN-Tier™ under such conditions. Also, do not operate the BN-Tier™ in very cold places or inside refrigerators where the temperature is 0°C (32°F) or lower.

#### 1.1.2 Check the state of the work site

Before using the BN-Tier™, check whether the state of the work site is as follows. If it is, always follow the instructions and prohibited items.

##### (1) Tidy up the work site

The BN-Tier™ may become short circuited if dust, etc. enters the main unit. If the battery pack is left exposed at a work site littered with nails, etc., it may become short circuited. When dust and /or nails etc. cannot be removed do not use the BN-Tier™ or leave the protective cover off the battery pack.

##### (2) Remove hazardous substances

Since the BN-Tier™ is an electric tool, it may spark and cause

an explosion or a fire if operated near gas cylinders, thinner, or explosive and other hazardous substances or in a place filled with inflammable gas, etc. Therefore, do not use the BN-Tier™ in places where such hazardous substances are present.



**! DANGER**

May cause an explosion or a fire ignoring this warning may cause death or serious injury. Never use the tool in places filled with inflammable gas or near hazardous substances of high flammability including Dust, Nails, Gas fumes.

(3) Do not use in puddle or where water splashes Since the BN-Tier™ is an electric tool, it may short circuit or cause an electric shock if dropped in water or splashed with water. Never use the tool in puddles or where water splashes.



**! DANGER**

Electric shock hazard. Ignoring this warning may lead to death or serious injury. Do not use this tool in a place possibly splashed with water or watery place involving the danger of soaking in water.

## 1.2 Maintenance of the Main Unit

Lubricate the main unit at the prescribed points before and after operation. Otherwise, the tool may fail to operate smoothly. The lubrication points are as indicated below. Apply one spray of lubricator prescribed separately using an atomizer.

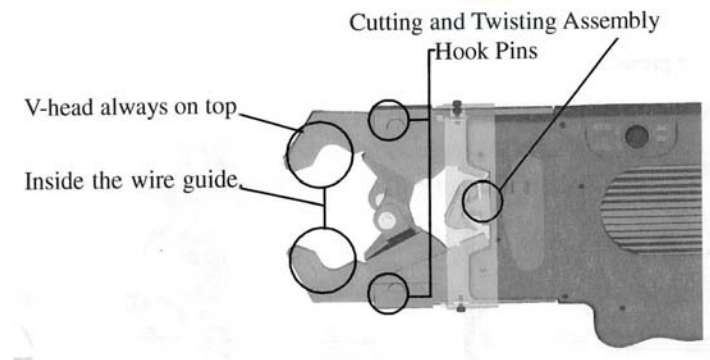

## 1.3 Removing and Replacing WireGuides

Simply pop out the hook pins pictured above (held by a spring.) Replace or change wire guide size by placing the wire guide back into the feed arms. Align the wire guide mounting holes and push in hook pins until they are surely fastened. Make sure the V-head on the wire guide is positioned at the top of the tier.

## 2. Method of Operating the BN-Tier™

### 2.1 Tying Procedure

(1) Turn the main switch on to turn on the power source. Always turn it off when not operating the tool.

(2) Hold the tying point with the wire guide of the main unit.

Hold the handle of the BN-Tier™ main unit with one hand. Insert the two wire guides at the end of the main unit into the spaces formed by the diagonal lines of the orthogonal reinforcing bars. Lower or push the BN-Tier™ under its own weight, and hold the tying point until the two wire guides close again.

(3) Pull the tying switch once to initialize the main unit

Upon turning the main switch of the BN-Tier™ on, the tool is initialized only once when the tying switch is pulled.

(4) Pull the tying switch to conduct tying.

Once initialized the BN-Tier™ performs tying each time the tying switch is pulled unless the main switch is turned off. So pull the tying switch lightly one more time to perform tying.

(5) Withdraw the main unit upward from the tying point

When tying is completed, withdraw the tool from tying point while holding the handle of the BN-Tier™.

(6) Adjust tying power with torque adjustment dial

If the tying is found too loose or too strong as the result of conducting the preceding check, adjust the tying power by turning the torque adjustment dial. The torque adjustment dial of the BN-Tier™ is initially set to 4 on shipment from the factory. When increasing the tying power with the torque adjustment dial, turn it in the direction of H (high) to a figure higher than 4. Conversely, when decreasing the power, turn the dial in the direction of L (low) so that the indicator reads less than 4. When making adjustment, move the dial carefully notch by notch. Hold the bars on the diagonal line

(7) Repeat operation (2) and (4) to (7) until the appropriate tying state is attained

Repeat (2) and (4) through (7) so that the appropriate tying state can be attained.

In this case, initialization (3) is not required since the power source is not turned on-off.

(8) Turn the main switch off to end operation. Upon completing a series of tying or when interrupting operation for a break or at the end of the shift, always turn the main switch off. When resuming operation, start from (1).

(9) Remove the battery pack from the main unit and put the battery terminal cap on. When removing the battery pack from the main unit, always put the battery terminal cap on the terminals. Leaving the terminals exposed may cause short circuit through contact with conductive material.

(10) Maintain, clean and lubricate the main unit. Upon com-

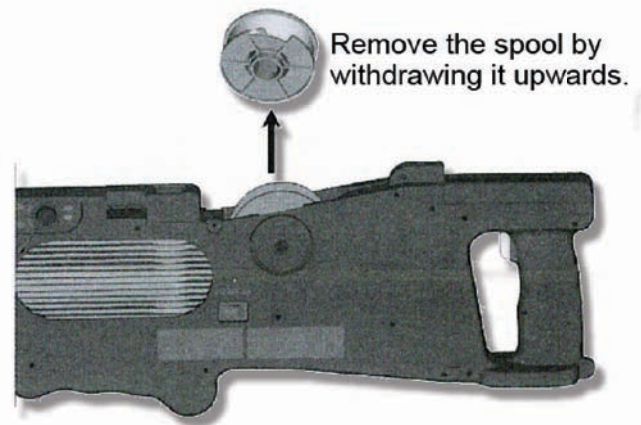

pleting operation, remove contamination from the components (particularly the grooves inside the wire guides) of the main unit. Always lubricate the tool as described in “1.2 Maintenance of the Main Unit, Part 2 Operation”.

## 2.2 Wire Spool Replacement Procedure

The following describes the wire spool replacement procedure.

### 2.2.1 How to Remove wire spool.

- Turn the main switch off.
- Press the gear release lever to release the feeding gears [1]
- Withdraw wire with the finger tips until the end comes out of the feeding gears [2]
- Withdraw wire spool straight upward from the main unit to remove

### 2.2.2 Wire Spool Setting Procedure

- Turn the main switch off
- Press in and set a new wire spool unit in the tool by locating it in the notch on the spool holder
- Remove the end of the wire from the wire stopper, correct the bend and straighten the wire. • Press the feeding gear release lever to lock the release feeding gears open [1]
- Pass the wire end through the wire-through hole, feeding gears and the pipe in this order [2]
- Set the feeding gears by pressing the feeding gear set lever [3]

## 2.3 Battery Pack Replacement Procedure

- Turn the main switch off
- Remove the battery pack from the main unit while pressing the battery pack removal buttons.
- Insert the charged battery pack until it locks.

## 2.4 Changing the Position of the Handle.

2.4.1 How to remove the handle The following drawing is how to remove the handle from main unit

2.4.2 How to reset the handle

The drawing is how to reset the handle in another position of main unit.

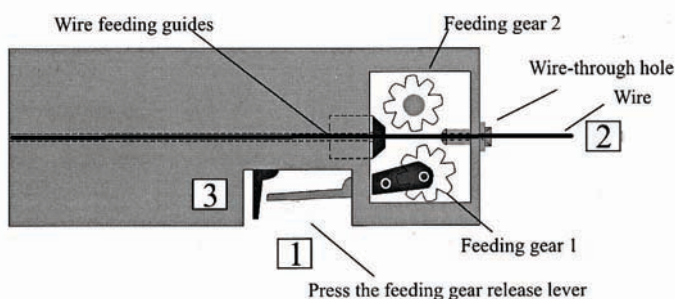

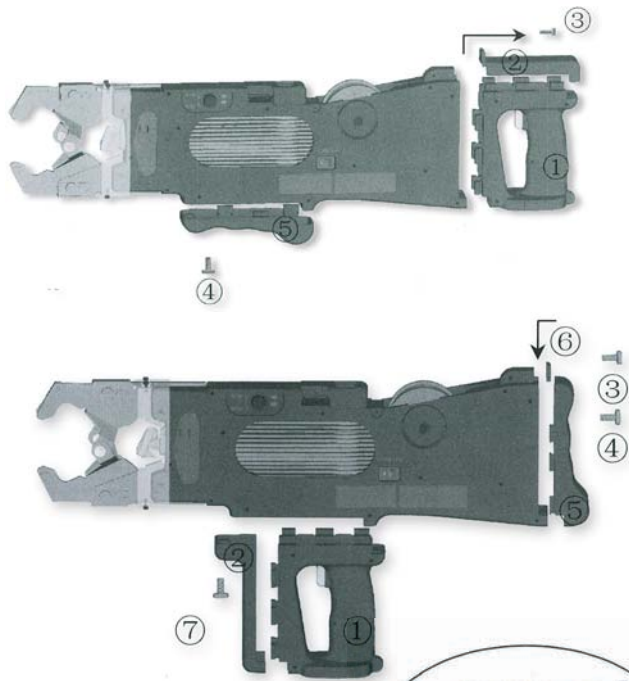

Remove the screw with a screwdriver. Split the handle cap from main unit as the arrow direction

Remove the screw with a screwdriver. Remove the handlecap. Split the handle from main unit as the arrow direction. Split the two plugs of connecting wire from main unit

Install the handle as the arrow direction. Install the inlay in the position as the drawing. Lock the two screws tight with a screwdriver. Connect the two wire plugs. Install the handle as the arrow direction. Install the handle cap as the arrow direction. Lock the screw tight with a screw driver

## 2.5 General Cautions on Operating

The following describe the general cautions on operating BN-Tier™. Always observe the cautions stated in each item.

(1) Do not press the tying switch of the BN-Tier™ holding toward anyone.

Operating the BN-Tier™ by holding it toward anyone may cause injury from contact with the wire. Never operate the tool toward other people.

(2) Do not apply the BN-Tier™ in lieu of other tools or for other purposes Do not use the BN-Tier™ for lifting or hammering other thing etc. instead of tying reinforcing bars. Otherwise, the main unit may be broken or damaged, causing injury.

## 2.6 How to Use the BN-Tier™ Efficiently

The following describes efficient use of the BN-Tier™.

### 2.6.1 Alternate Tying

When using the BN-Tier™ for tying, higher strength can be obtained by crossing it at the crossing point of the reinforcing bars for alternate tying as shown in the figure.

### 2.6.2 Double Crossed Tying

When tying power differs between reinforcing bars, double

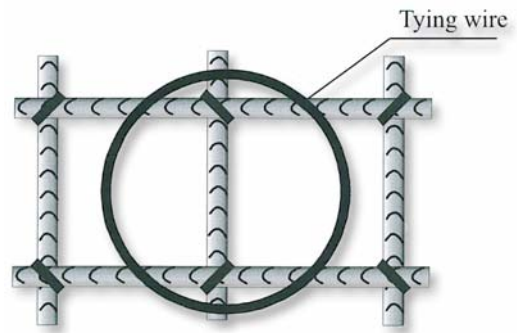

crossed tying improves the tying strength. To achieve this, bend the wire tied first in the direction of the reinforcing bars, then perform the second tying.

## Part 4 Battery Charger

### 1. Names and Functions of the Battery Charger Components

To charge the BN-Tier™ battery pack, always use a prescribed battery charger.



### 2. Specifications of the Battery Charger

The specifications of the battery charger are as follows.

### 3. Battery Pack Charging Procedure

Model No.	BN-12VCHGR
Description	Ni-Cad Battery charger
Input Voltage	110-240VAC, 50/60Hz
Power Consumption	60W
Charging System	16V, 3A
Service Battery	BN-12VCAD Special Battery Pack
Service Temperature	32° to 104° F (0°~ 40° C)
Service Humidity	90% Max
Storage Humidity	90% Max
Charging Time Approx.	Approx. 30 minutes

### 3.1 Power Source for Battery Charger

Always use a AC power source for the battery charger. Never use a DC power source or an engine for the battery charger. When using the battery charger outdoors, always use appropriate extension cord.

## 3.2 Service Environment of Battery Charger

Do not Charge the battery pack if the temperature is under 32° (0° C) or over 104° (40° C).

Do not use the battery charger near flammable liquid or gas.

Do not place the battery charger cord close to hot, oily or sharp object.

### 3.2.1 Cautions on using battery charger

Do not carry the battery charger by the cord extract it from the socket by pulling the cord. Do not place the battery charger in an area where the cord may be damaged by being stepped on, hooked or subjected to a strong force.

Do not cover the battery pack and /or charger with cloth during charging. Do not touch the power plug of the battery charger with wet hands. Do not use the battery charger in the rain, or in moist or wet places.

When charging the battery pack, do not forget and leave it being charged for an extended time. When charging battery packs in succession, turn the power source off for a while to allow the battery charger to cool down.



### ! CAUTION

Battery charger may short circuit. Ignoring this caution may cause a hazard resulting in not so serious injury and/or situations that require financial compensation.

### 3.2.2 Cautions on storing battery charger

When not in use, store the battery charger in the prescribed place after unplugging the power cord.

Do not leave the battery charger and packs at the work site or in direct sunlight.

Store the battery charger in a dry, elevated place out of the reach of children or in a lock-up storage.

## 3.3 Battery Pack Charging Procedure

3.3.1 Check and clean the battery pack inlet plug of the battery charger

3.3.2 Insert a battery pack to the prescribed position in the battery charger until it stops

3.3.3 Check the lighting and blinking of the indicating lamp

The indicating lamp blinking red and green, it means standby or battery pack is faulty. The indicating lamp is red, it means charging on. When the green lamp is lighting, charging has been completed.

3.3.4 Place the battery terminal cap on the terminals of charged battery pack

When using the charged battery pack immediately, the above procedure is not required as it is installed in the main unit as it is.

Do not leave the charged battery pack at the work site or in direct sunlight. Otherwise, it may cause short circuiting, leak-

age of the battery electrolyte, etc., possibly leading to toxic gas generation.

Store charged battery packs in the tool pack and /or other prescribed place.

## 3.4 General Cautions on Battery Charger

The following are general cautions on the dedicated battery charger for the BN-Tier™.

Always observe the cautions stated in these items.

3.4.1 Allow the battery charger to cool down for one hour after charging three times in succession

If three battery packs are charged in succession, allow the battery charger to cool down for one hour to prevent overheating.

3.4.2 Always use the battery charger indoors because it is vulnerable to rain and moisture.,

## 4. Maintenance of the Battery Charger

The following describes the procedure for maintaining the battery charger.

### 4.1 Daily Inspection of the Battery Charger

The dedicated BN-Tier™ battery charger is frequently used for charging battery packs.

There are three check points for using this battery charger; namely, the power cord, the battery pack inlet plug, and the indicating lamp. If the power cord is peeled or damaged, it may cause a short circuit leading to a fire. If the battery pack inlet plug is clogged with foreign objects, charging will be disabled. And if the indicating lamp is burnt out, it will not light up, making it impossible to tell the state of the charger. Therefore, always check and clean these three points before and after use.

Since the battery charger has electrical characteristics, never clean it with wet cloth or wash it with water. Do not clean the battery pack inlet terminals with the tip of a screwdriver or other conductive tool. Always unplug charger prior to cleaning.

### 4.2 After Sales Service of the Battery Charger

After sales service of the battery charger is basically the same as for the BN-Tier™ which is described as follows. If abnormalities persist after taking measures according to “Part 4 Troubleshooting”, contact our sales office for repair. Your attention is directed to the difference in repair expenses to be borne by you depending on whether or not the date of the repair request is within the warranty period.



### ! WARNING

Battery charger may become faulty or cause injury due to burning and/or short circuiting because of overheating. Ignoring this warning may cause a hazard leading to death or serious injury.

## Part 4 Troubleshooting

### 1. Troubleshooting During Pre-operational Checking of BN-Tier™

If any trouble is detected during various checking procedure prior to the operation of BN-Tier™, here is a list of probable causes troubleshooting. It is a good idea to call our Service Center prior to sending your tool to us for repairs.

Content of Trouble	Probable Cause	Troubleshooting
<b>Weather Conditions</b>		
<ul style="list-style-type: none"> <li>* Rain, thunderstorm, snow or Gale</li> <li>* High temperature and relative humidity</li> <li>* Very low temperature</li> <li>* Under direct rays of the sun</li> </ul>	Attributable to short circuit, over-heat, fuming, burns, falling, failure and other troubles	Suspend the tying operation until the weather condition turns favorable
<b>Work Site Condition</b>		
<ul style="list-style-type: none"> <li>* Littered and disorderly</li> <li>* Hazardous substance nearby</li> <li>* Work on the elevated level</li> <li>* Work under very low or high temperature</li> <li>* Inflammable substance nearby</li> <li>* Splashed by water</li> <li>* Unstable footing</li> </ul>	Attributable to short circuit, over-heat, fire, explosion, falling, failure and other troubles	Proceed with the tying operation after tidying up the work site. If hazardous or inflammable substances cannot be removed, stop tying operation in such a spot
<b>Object of Work</b>		
<ul style="list-style-type: none"> <li>* Wood and/or synthetic resin instead of reinforcing bars</li> <li>* Total diameter of the objects is over 64 mm or 2.5"</li> </ul>	Possibilities of the failure of tying operation	Do not proceed with tying operation because it is off limit for tool operation
<b>Wire Spool</b>		
<ul style="list-style-type: none"> <li>* Rust generated on wire</li> </ul>	May cause wire to be ruptured immediately after tying or other problems	Replace wire spool
<b>Battery Pack</b>		
<ul style="list-style-type: none"> <li>* Promptly runs out of storage energy</li> </ul>	The end of the life time for the battery pack	Replace battery pack
<ul style="list-style-type: none"> <li>* Charging time is too long</li> </ul>	Storage for an extended period of time	Charge it for 20 hours
Content of Trouble	Probable Cause	Troubleshooting
<b>Switch system</b>		
<ul style="list-style-type: none"> <li>* Main switch is not operable</li> </ul>	<ul style="list-style-type: none"> <li>* Damaged switch</li> </ul>	<ul style="list-style-type: none"> <li>* Contact your sales office</li> </ul>
<ul style="list-style-type: none"> <li>* Pressing the main switch does not turn the tool ON-OFF.</li> </ul>	<ul style="list-style-type: none"> <li>* Battery Pack not correctly installed</li> <li>* Battery pack not installed</li> <li>* Faulty main switch</li> <li>* Shortage of the battery pack capacity</li> <li>* Malfunction of the main circuit board</li> </ul>	<ul style="list-style-type: none"> <li>* Install the battery pack</li> <li>* Contact your sales office</li> <li>* Charge the battery pack</li> <li>* Contact your sales office</li> </ul>

* Pulling the tying switch does not cause the tool to perform tying	* Faulty switch * The guide is not closed * Shortage of the battery pack capacity	* Contact your sales office * Close the guide * Charge the battery pack
*Tying switch is not operable	* Clogging with foreign objects * Damaged switch	* Remove foreign objects, etc * Contact your sales office
* Torque adjustment dial is not operable	* Clogging with foreign objects * Damaged switch	* Remove foreign objects, etc * Contact your sales office
* Turning the torque adjustment dial does not change the LED indication.	* Loose dial fixing screws * Faulty LED indicating lamp	* Tighten the screws * Contact your sales office
* Changing the torque adjustment dial does not change the tying power	* Application to other type of reinforcing bars than specified * Malfunction of the circuit board * Using another type of wire other than BN-Wire spool	* Contact your sales office
* LED indicating unit indicates nothing	* Main switch is not turned ON * Battery pack not installed * Malfunction of circuit board	*Turn the main switch ON * Install the battery pack * Contact your sales office
* The feeding gear set lever and the gear release lever are not operable	* Clogging of foreign objects * Lever malfunction	* Remove foreign objects * Contact your sales office
* Battery pack remove button not operable	* Clogging of foreign objects * Battery malfunction	* Remove foreign objects * Replace
<b>BNTier Tool Main Unit Related</b>		
* Wire guide does not close	* Clogging of foreign objects * Damaged or abnormality of the guide	* Remove foreign objects * Replace
* Protective cover is cracked	* Stopper making contact with the protective cover * Cover collided with other object	* Replace the wire guide * Replace the protective cover
* The catch of the tying unit fails to catch wire during tying operation	* Used other type of wire than BN-Wire spool	* Use BN-Wire spool
* Wire is not cut during tying operation	* Used other type wire than BNTier wire spool * Wear of the cutter	* Use BN-Wire spool * Contact your sales office
* Wire is not tied during tying operation	* Used other type of wire than BN-Wire spool	* Use BN-Wire spool
* Wire feeding gears slip	* Used other type of wire than BN-Wire spool *Wear of feeding gears	* Use BN-Wire spool *Contact your sales office
* Wire feeding gears do not operate	* Motor lock * Clogging of foreign objects	* Contact your sales office * Remove foreign objects
* Battery pack cannot be removed/installed	* Used other type of battery than the dedicated battery pack * Deformation of battery pack	* Use dedicated battery pack * Replace
* The feeding gear set lever and the gear release lever are not operable	* Clogging of foreign objects * Lever malfunction	* Remove foreign objects * Contact your sales office

<b>Error Messages</b>		
<b>Blinking LED Indication</b>	<b>State of Indication</b>	<b>Remedial Procedures</b>
'0' and 'E' blink alternately	Battery pack charge time is up	Turn the main switch OFF and replace with charged battery pack
'1' and 'E' blink alternately	The gear release lever is not fully returned.	Turn the main switch OFF and return the gear release lever
	Wire spool is not properly inserted to the spool holder.	Turn the main switch OFF and set wire spool correctly to the spool holder
'2' and 'E' blink alternately	Wire is entangled with the hook because of defective tying	Turn the main switch OFF and remove entangled wire using nippers
	The guide is open during operation	
'3' and 'E' blink alternately	Motor is locked or abnormal torque is applied	Turn the main switch OFF and eliminate the cause of the locked motor
'4' and 'E' blink alternately	Overheat or malfunction of the control circuit board and/or motor	Turn the main switch OFF immediately, remove the battery pack from the main unit and stand by until main unit cools down. When the main unit is cooled, resume operation. If the alternate blinking of 0 and 4 persists, stop the operation and contact your sales office.

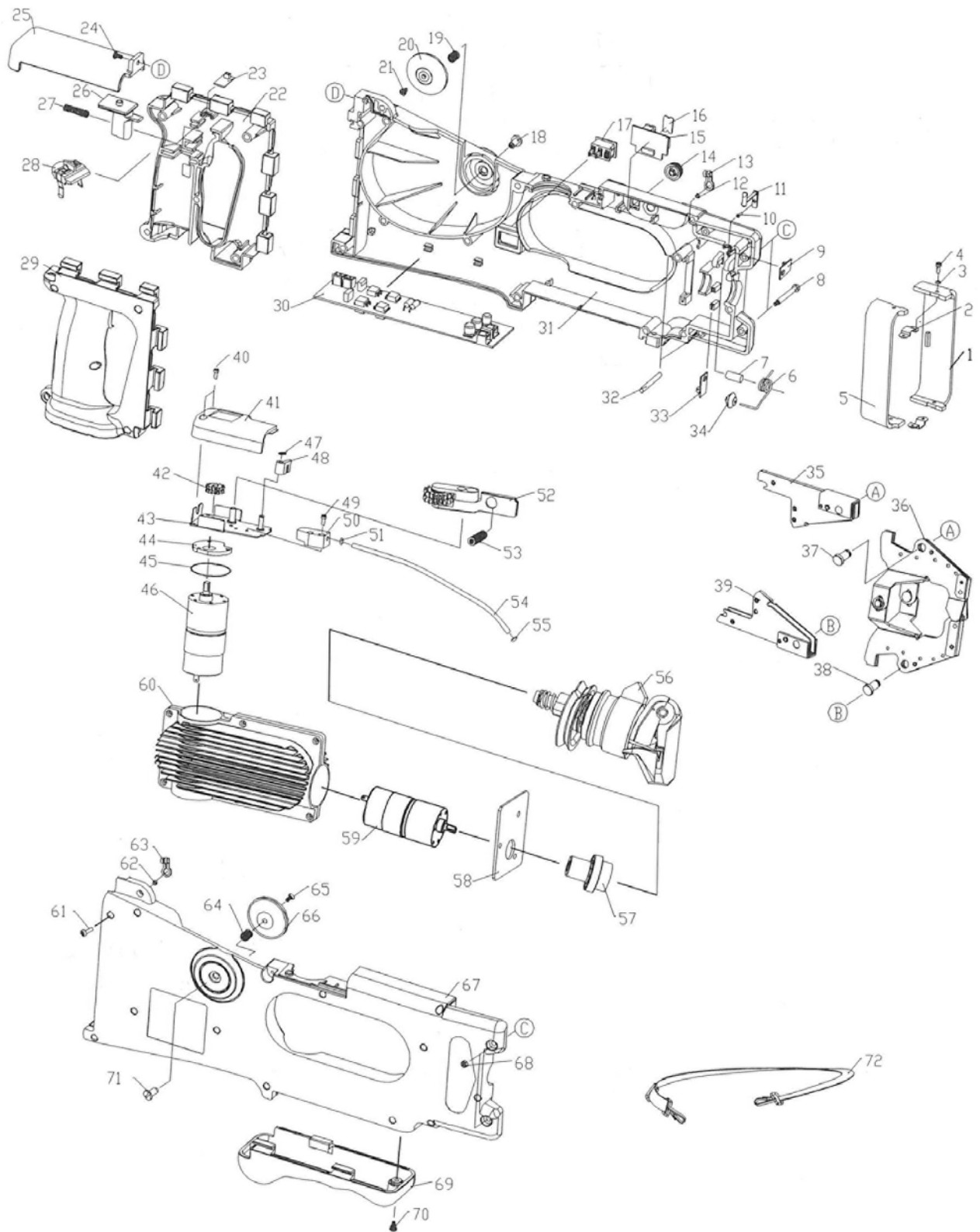

• BN-TIER #BNT-64 VERTICAL WORK PARTS BREAKDOWN

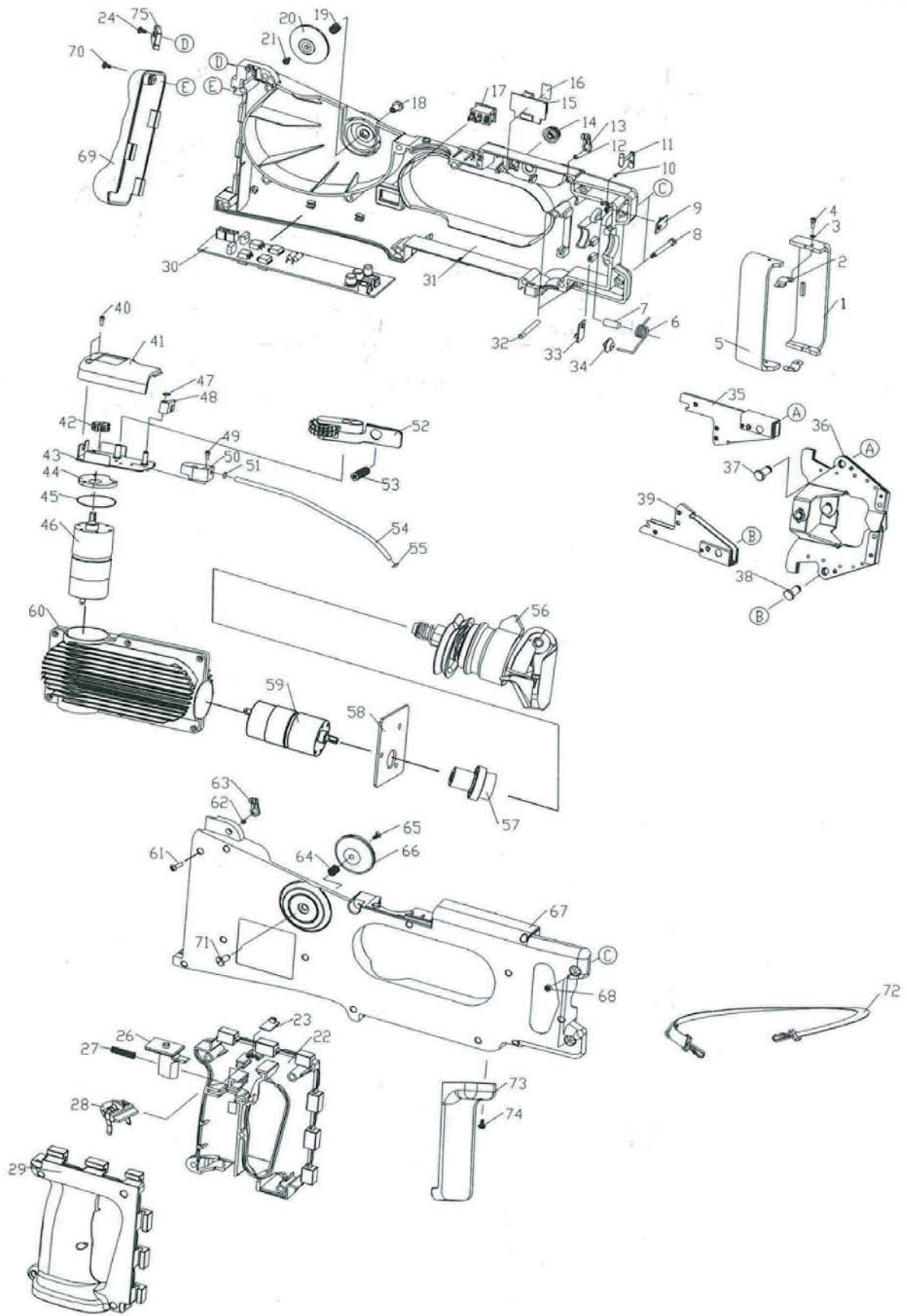

• BN-TIER #BNT-64 HORIZONTAL WORK PARTS BREAKDOWN

## Parts List

Key	DESCRIPTION
1	Guard (Left) (BNT-001)
2	Guard Clip (BNT-002)
3	Washer (BNT-003)
4	Screw (BNT-004)
5	Guard (Right) (BNT-005)
6	Wrest Spring (BNT-006)
7	Axis (BNT-007)
8	Guide Rail Bolt (BNT-008)
9	Sensor Board (BNT-009)
10	Screw (BNT-010)
11	Locking Arm (BNT-011)
12	Spacer (BNT-012)
13	Belt Fastener (BNT-013)
14	Torsion Adjuster (BNT--14)
15	Display Circuit Board (BNT-015)
16	Shade (BNT-016)
17	Power Switch (BNT-017)
18	Aluminum Screw (BNT-018)
19	Press Spring (BNT-019)
19-1	Washer (not shown) (BNT-019-1)
20	Bobbin Holder (Left) (BNT-020)
21	Screw (BNT-021)
22	Handle 1 (BNT-022)
23	Sensor Board (BNT-023)
24	Screw (BNT-004)
25	Handle Cover I (BNT-025)
26	Trigger (BNT-026)
27	Press Spring (BNT-027)
28	Battery Connector (BNT-028)
29	Handle 2 (BNT-029)
30	Main Circuit Board (BNT-030)
31	Tier Cover (Left) (BNT-031)
32	Stopper Pin (BNT-032)
33	Sensor Board (BNT-033)
34	Cam (BNT-034)
35	Hook Arm (BNT-035)
36	Bracket (BNT-036)
37	Hook Pin (BNT-037)

38	Hook Pin (BNT-037)
39	Feed Gear (BNT-039)
40	Screw (BNT-024)
41	Motor Cover (BNT-041)
42	Motor Gear (BNT-042)
43	Motor Bracket (BNT-043)
44	Motor Spacer (BNT-044)
45	O Ring (BNT-045)
46	Feed Motor (BNT-046)
47	C-Clip (BNT-47)
48	Lock Lever (BNT-048)
49	Screw (BNT-021)
50	Guide (A) (BNT-050)
51	O Ring (BNT-051)
52	Gear Block Assembly (BNT-052)
53	Spring (BNT-053)
54	Guide Pipe (BNT-054)
55	O Ring (BNT-051)
56	Cutter-Twist assem. (BNT-056)
57	Transmission Shaft (BNT-057)
58	Motor Plate (BNT-058)
59	Motor (BNT-059)
60	Radiator (BNT-060)
61	Bolt (BNT-004)
62	Nut (BNT-062)
63	S. Strap Fastener (BNT-063)
64	Press Spring (BNT-019)
65	Screw (BNT-021)
66	Bobbin Holder (R) (BNT-066)
67	Case (R) (BNT-067)
68	Nylon Nut (BNT-068)
69	Handle cover II (BNT-069)
70	Bolt (BNT-024)
71	Aluminum Screw (BNT-018)
72	Shoulder Strap (BNT-072)
73	Handle Cover 3 (BNT-073)
74	Screw (BNT-024)
75	Inlay (BNT-075)
	Battery Pack (BN-12Vcad)
	Battery Charger (BN-12VCHGR)